

VIRGINIA PLUMBING & MECHANICAL INSPECTORS ASSOCIATION

# VPMIA

*Strength Through Leadership, Education and Unity*

45<sup>th</sup>

# Annual School of Instruction

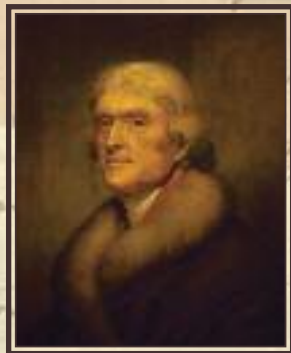

*April 9 – 11, 2008*

*Charlottesville, VA*

# ICC® Plumbing, Mechanical, Fuel Gas (PMG) Portfolio

**Outstanding products designed to fit your needs.**



**Products**—ICC Code books & electronic media, references, training tools and other industry publications provide everything you need to know about Plumbing, Mechanical and Fuel Gas Codes.

**Training**—ICC offers industry leading customized training programs that can help keep you current on the latest codes and code changes. These programs are offered where and when you need them—on-site, online, or on the phone.

**Certification**—ICC Certification services are nationally recognized, with easy, web-based registration and results reporting. Keep certifications up-to-date and your career on track with ICC Certifications.

**Membership**—Join now and save on all ICC products and services, benefits include free code opinions and more discounts.

Find out more about ICC Plumbing, Mechanical, and Fuel Gas (PMG) products and services at the PMG Resource Center.

**[www.iccsafe.org/PMG](http://www.iccsafe.org/PMG)**  
**1-888-ICC-SAFE (422-7233), x4PMG**  
**Email: [PMGResourcecenter@iccsafe.org](mailto:PMGResourcecenter@iccsafe.org)**



Repairs - Remodeling  
Commercial New Construction  
Backflow Installations, Repairs & Certification

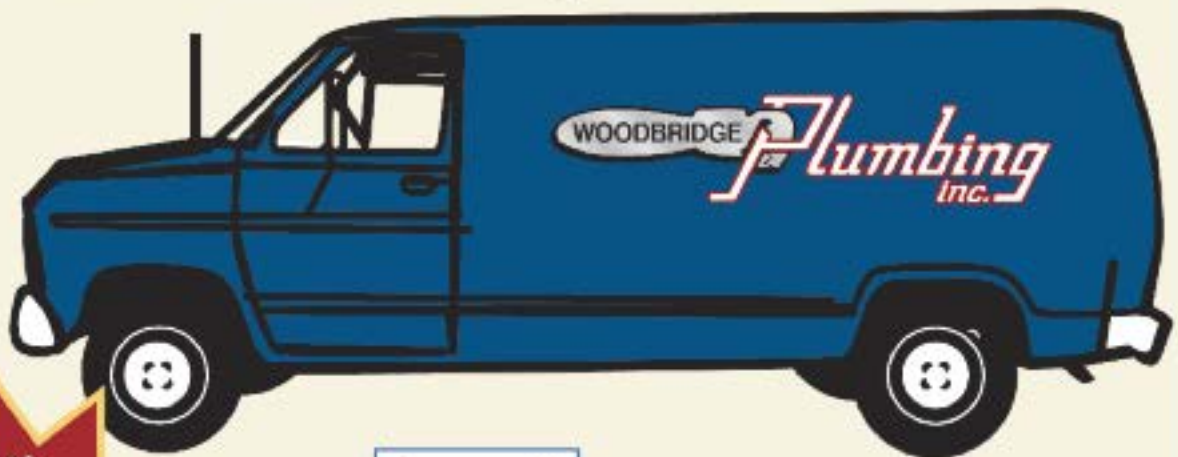

2006  
Prince William  
Regional Chamber  
of Commerce  
"Large Business  
of the Year"

Local

**703-494-9666**

Toll-Free

**1-800-FIX-MY-LEAK**  
**(1-800-349-6953)**

*Quality Service Since 1973*

Members of BBB, PHCC and PMPV

2705 Code Way • Woodbridge, VA 22192 • [www.woodbridgeplumbing.com](http://www.woodbridgeplumbing.com)

Willie Johnson, President • Thomas Wood, CEO



INTERNATIONAL  
CODE COUNCIL®

People Helping People Build a Safer World™



"I am the ICC."



"I am the ICC."



"I am the ICC."



"I am the ICC."

## ARE YOU?

Join your peers. Become a member of the International Code Council® now, the organization that can help you build your career and your future.

- Discounts on ICC products and services.
- On-site and on-line training to enhance your knowledge and skills.
- Access to expert code opinions.
- Extensive peer-to-peer collaboration opportunities.

**JOIN NOW! [www.iccsafe.org/areu](http://www.iccsafe.org/areu)**  
**QUESTIONS? 1-888-ICC-SAFE (422-7233), x33804**



## Welcome to the 45<sup>th</sup> Annual Virginia Plumbing & Mechanical Inspectors Association School of Instruction in Charlottesville, Virginia.

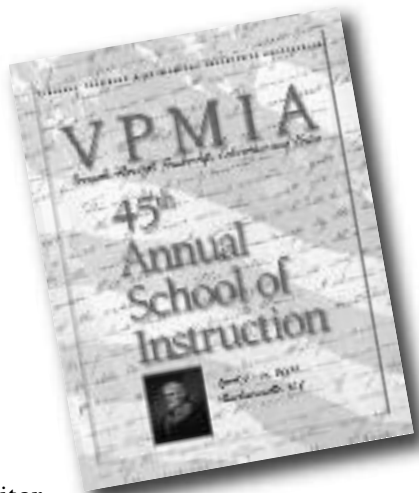

From the Editor

*This is your annual resource book for VPMIA. I encourage each and every member, Active and Associate, to take the time and read the entire publication. It is important for all to be aware of VPMIA's History, Constitution, By-Laws, Code of Ethics/Mission, and Strategic Plan. And don't forget about the President's Corner to see what we have accomplished during this past year.*

*Last, but not least, there is something new in this publication — two cutting-edge, technical articles; the first authored by Lee Clifton of the International Code Council, and the second by Wes Davis of the Air Conditioning Contractors of America. We are grateful for their contributions.*

Ron Bladen

### CONTENTS

Index to Advertisers	5
President's Corner	6
History	7
Charter Members	9
<b>2008 School of Instruction Program</b>	<b>10</b>
Dedication	11
Resolutions	12
Code of Ethics/Mission	13
Constitution & By-Laws	14
2007-8 Ladies Auxiliary Roster	18
Awards Roster	20
Past Presidents	20
Acknowledgements	22
Strategic Plan	23
Upcoming Events	24
<hr/>	
<b>The International Plumbing Code: Protecting the Environment</b>	<b>27</b>
<i>By Lee Clifton</i>	
<b>Reviewing HVAC Designs</b>	<b>30</b>
<i>By Wes Davis</i>	
<hr/>	
Officers, Directors and Committee Chairmen	35
2007-8 Membership Roster	36
2007-8 Associate Membership Roster	49
New Member Application	51

### VPMIA gratefully acknowledges the support of its advertisers, listed below:

International Code Council . . . . .	IFC	Harry Eklof Associates, Inc. . . . .	.26	Fitzgerald Art & Design . . . . .	.47
Woodbridge Plumbing . . . . .	.3	New Shelter Construction . . . . .	.29	VPMIA AD . . . . .	.52
International Code Council . . . . .	.4	GSSN . . . . .	.32	Ductmate . . . . .	.53
L.A. Lacy, Inc. . . . .	.19	L&D Associates, Inc. . . . .	.39	ACME Construction . . . . .	.54
Southern Air . . . . .	.21	E&E Plumbing and Heating . . . . .	.40	PHCC . . . . .	.IBC
W.E. Brown, Inc. . . . .	.22	Leonard-Splaine . . . . .	.43	ACCA . . . . .	.BC
The Plumbing Dr. . . . .	.25	Beck Cohen . . . . .	.45		

# — President's Corner —



It's been my privilege and honor to serve as your President this past year. I want to thank the VPMIA members for giving me the opportunity to lead the organization and keep it moving forward, by standing behind our Code of Ethics and living our Vision, Mission, and Strategic Mission. As we look toward a bigger and better future for our organization, we will keep growing and striving for our Strategic Plan and Mission. Also working with all my fellow board members, district directors and committee chairs has made this another successful year for VPMIA.



This year has been busy again with several members teaching code module classes, and some even traveling around the country teaching. These members need a big pat on the back for doing such a great job and making sacrifices by being away from home and their jobs. We are an organization of committed, dedicated, and very passionate inspectors in making sure the health, safety, and welfare of all Citizens is accomplished. We have several members involved with several other organizations and committees, along with being active in the Region 7 ICC Chapter working with several states to help bring consistency and uniformity of the codes throughout the country. The organizations has been preparing for the upcoming code hearings in California, with many members writing new code changes and having meetings to see as a organization what our positions are on the new changes. Several members will attend the code hearings and will be participants on code committees, such as Plumbing, Fuel Gas, and Mechanical. Remaining active in the organization is why we have been successful in the code development

process and are well respected throughout the state of Virginia and across the country as well. This takes daily and year round involvement to maintain a strong, prosperous, and successful organization. At this time VPMIA is financially strong and scholarship funds are available for members to attend code hearings. This is your opportunity to step up, serve and get involved with what we are all about.

VPMIA has two Schools of Instruction per year so the members and contractors can receive some of the best training around and keep up

on their required hours needed to maintain their inspector's certifications and tradesman licenses through DHCD and DPOR. Also this year the following organizations, VPMIA and VBCOA, are planning another joint conference with outstanding training, with the common goal that uniformity is met throughout the state and the health, safety and welfare of all Virginia citizens is accomplished.

In closing, It has been a pleasure and great opportunity to serve as VPMIA President. I want to thank of the officers and directors and members who helped me make this a successful year. May we all continue to grow in knowledge and experience.

Thank you all,

**Dennis Martinelli**  
President  
VPMIA

# — History —

**ORIGINAL HISTORY BY PAUL C. KING.  
COMPILED FROM THE MINUTES OF THE  
VPIA MEETING APRIL 14, 1962**

## A small group...

of Virginia plumbing inspectors met in 1959 following a seminar at VPIA in Blacksburg. The group discussed the possibility of forming a statewide association for the purpose of dissemination of information touching on new methods, materials and testing procedures used in the plumbing and heating profession.

Following the three-day seminar the inspectors returned to their respective jobs. Being dedicated to their profession, these men contacted individual members of the Virginia State Master Plumbers Association meeting. Cards were mailed asking the inspectors if they were interested in forming such an association.

The first meeting of the group, which would be called The Virginia Plumbing Inspectors Association, took place April 14, 1962 at the Hotel John Marshall in Richmond. Attending were fourteen plumbing inspectors and three associate members. (These names are published as Charter Members.) The first order of business for the group was to name a temporary chairman, Mr. Mannion, followed by nomination and election of officers.

Officers elected were: President, Charles E. Mannion, Richmond; Vice President, Paul C. King, County of Fairfax; Secretary, John B. Mason, Richmond; Treasurer, James B. Jones, Jr., Martinsville; and Sgt. At Arms, E. R. Carr, Winchester. Board of Directors named included: U.E. Allen, Jr., Portsmouth; Frank B. Bosman, County of Arlington; and Gordon Dameron, Danville.

A committee consisting of inspectors King, Chairman, Carr and Cooper was appointed and instructed to draw up the proposed by-laws for the association. A general discussion followed covering the aims and purposes of the organization. A date was set for the

next meeting and the group adjourned its meeting to join the Master Plumbers Association, which was in session at this time.

### **By-Laws Adopted**

VPIA met November 3, 1962 at 1014 East Broad Street, Richmond.

The By-Laws Committee presented its report, which was duly adopted. Article II of those by-laws set forth the purpose of the organization:

- A. Cooperate in the formulation of Virginia Plumbing Code Standards.
- B. Promote uniform understanding and application of all city, town and county plumbing codes.
- C. Secure and promote uniform administrative ordinances and inspection methods.
- D. Promote closer cooperation between inspectors, inspection departments, health departments, plumbing contractors and the public.
- E. Promote and improve the standards of the profession of plumbing inspectors.
- F. To institute and maintain a central organization to properly test new materials and methods to be used in this Commonwealth.

### **School of Instruction**

The Association embarked on a program when Paul C. King served as proxy which has proven to be well accepted by those men serving in all phases of the plumbing industry. Known as "School of Instruction and Conference," the program owes its success to D. Paul Jack, Hampton. Through his efforts, almost single-handedly, Mr. Jack managed to obtain speakers from Texas, across the south, and as far west as Wisconsin. The first annual School of Instruction and Conference was held in Hampton on April 17 and 18, 1964 and was a huge success. Each succeeding year has found

the meeting generating more interest in the plumbing profession.

Inspectors have found that the annual school and conference has given us the opportunity to carry out some of the aims of VPIA, namely: "the dissemination of new methods and materials" on a state-wide basis. Our speakers are not only considered experts in their fields but they also present facts which help to generate enthusiasm among those association members interested in promoting the plumbing profession.

### **Executive Secretary**

In 1969 the Board of Directors appointed an Executive Secretary with the responsibilities to direct the school for Qualified Plumbing Inspectors and to publish a newsletter for the purpose of keeping inspectors abreast with the workings of the association and other related items of interest that inspectors in Virginia and the southeastern states should be concerned with. Thus far the newsletter has accomplished its purpose and its present circulation includes eighteen states.

We are proud to be members of VPIA. The knowledge we have gained during the past years has made it possible for us to be cognizant that the plumbing profession is indeed one of the leading 'trades' in the building industry.

### **History Up-Date**

In 1986, the Board of Directors instructed the committee on by-laws to update and revise the by-laws to meet and comply with the present day regulations. President John W. Thurston appointed Edward J. Baldwin, Jr., Chairman and D. Paul Jack as part of a two-member committee to study and propose the needed changes.

\*\*\*

*(continued on next page)*

*(History, continued)*

On April 1988, at the Twenty-Fifth Annual School of Instruction as the yearly conference had now come to be known, after two years of study and consideration by the committee and board of directors, the amended by-laws were approved and adopted by the voting membership of the Virginia Plumbing Inspectors Association.

On July 21, 1990, at the Association's summer meeting, the voting membership of the Virginia Plumbing Inspectors Association voted unanimously to change the name of the Association to the Virginia Plumbing and Mechanical Inspectors Association. The change was felt necessary because of the number of jurisdictions within the Commonwealth of Virginia having separate mechanical inspection divisions whose inspectors were seeking educational opportunity. It was the feeling of the membership that this Association could provide that opportunity of educational instruction.

In-as-much as there were some other concerns regarding the by-laws, the Committee on By-Laws, consisting of Edward J. Baldwin, Jr., Chairman, Kenneth R. Snyder, Sr. and D. Paul Jack, Vice Chairmen, William F. Hines, Dennis W. McNaughton, Thomas C. Roberts and Paul M. Adams, Executive Secretary, was directed by President Robert M. Broome to study and submit amendments to the by-laws reflecting the name change and other necessary changes needed to include the mechanical personnel. Through the course of the study, an executive board, four regional directors positions and specific duties of the presidential appointed chairpersons were incorporated. The amended by-laws were approved by the committee on September 6, 1990 by the board of directors on October 6, 1990 and by the general membership in December 1, 1990.

After a period of working under the executive board, which consisted of the elected officers and the four regional directors, the board of directors instructed the Committee on By-Laws

to once again review and recommend any needed changes deemed necessary. This resulted in more changes being proposed, the most significant being a change in the fundamental membership and voting rules. The system used since the beginning of the Association was that of jurisdictional membership with a limit of one vote per jurisdiction. The proposed amendments included a change to individual membership with one vote per active member (associate members must remain without a vote in order to protect chapter membership in building officials and code administrations international).

The progress of these amendments, of the proposals and counter proposals, spanned the terms of three presidents and three by-laws committees. The first action of the general membership, which resulted in a change, was made on March 26, 1994 at the conclusion of the Thirty-First Annual School of Instruction. That change eliminated the executive board and dictated meeting schedules. Action was taken on June 25, 1994 which clarified the responsibilities of various officers and both board and presidential appointments. The action which resulted in the current by-laws was taken at the winter meeting on December 3, 1994.

During the course of the by-laws change process, another transition for our Association was under way. In the spirit of promoting closer cooperation between inspectors, inspection departments and plumbing contractors, the membership decided to hold the Twenty-Eighth Annual School of Instruction in Norfolk. The dates were April 11, 12, and 13, 1991 and this coincided with the annual meeting of The Virginia Cross Connection Control Association, The Virginia Association of Plumbing, Heating and Cooling Contractors, and the Richmond Chapter of The American Society of Plumbing Engineers. Although the various associations involved held their own separate educational and business meetings, the trade exposition, where new products and materials could be analyzed and

evaluated in a "hands-on" manner, was a central focal point. This cooperation has proven to be a successful format and continues with most of the same organizations being involved.

The Virginia Plumbing and Mechanical Inspectors Association was founded for the purpose of education and communication. As further evidence of this commitment, the annual summer meeting was expanded, beginning in 1994, to include a day of technical training. With the consolidation of BOCA, ICBO and SBCCI into the International Code Council and subsequent adoption of the International Codes in Virginia, the potential for growth has expanded and we have taken up the challenge. We continue to be a leader in the support of education and code development. In 2002 we received the BOCA Chapter of the Year Award for excelling in educational opportunities, membership and participation in BOCA activities. In 2004, we received the Directors Award from the Virginia Department of Housing and Community Development in recognition of our members' participation in the development and delivery of plumbing and mechanical code educational modules for the Virginia Building Code Academy as well as conducting statewide training in plumbing, mechanical and fuel gas code requirements and service on the Building Code Academy Advisory Committee. In 2005 the Association was honored to accept a Chapter Merit Award from the International Code Council.

Closer ties with our partners in code development and administration both within Virginia and throughout the country have developed. VPMIA, along with the Virginia Building and Code Officials Association and the Virginia Fire Prevention Association came together in October of 2005 for the first ever joint conference. The educational seminar lasted for four days with dual tracks offering a wide variety of training from Legal Aspects of Code Enforcement to Hydrogen Refueling Station installations. We



# — VPMIA Charter Members —

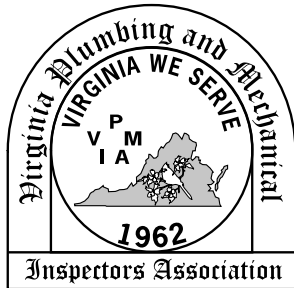

## ACTIVE

- \* MR. U. EARL ALLEN
- \* MR. E. W. BAUGHAN
- MR. FRANK BOSMA
- \* MR. E. R. CARR
- \* MR. EUGENE COBANKS
- MR. M. D. COOPER
- \* MR. GORDON I. DAMERON
- \* MR. JAMES B. JONES, JR.
- \* MR. PARL C. KING
- \* MR. CHARLES E. MANNION
- \* MR. JOHN B. MASON
- MR. CURTIS H. NUNALLY
- \* MR. WILLIAM G. PRIDDY

## ASSOCIATE

- \* MR. JOSEPH E. BAKER
- \* MR. T. C. BROWN
- \* MR. CHARLES E. WESSMAN

## LADIES AUXILIARY

- \* MRS. RUTH BIANCO
- \* MRS. ANN COBANKS
- \* MRS. IRMA DRAKE
- MRS. RUTH JACK
- MRS. MARGARET KING
- MRS. SONIA SCHROECK
- MRS. SHIRLEY WILLIAMS

\* Indicates Deceased

have strengthened our Association by focusing on our responsibilities and purpose. Our foundation now consists of a vision, a mission and a strategic plan to further our goals. Thus we go onward, not knowing what challenges are to be faced tomorrow, but confident that through our dedication to learning today, we will be prepared.

## Making History

*The VPMIA, VBCOA, VFPA Joint Conference*  
On October 21, 2005 the Virginia Plumbing and Mechanical Inspectors Association together with the Virginia Building Officials Association and the Virginia Fire Prevention Association held the first ever Joint Code Conference in Hampton, Virginia at Hampton's brand new Conference Center. The conference was a four day event that offered training in all areas of code enforcement. The Conference gave the participants an opportunity to



network with each other, develop code knowledge, and earn valued continuing education credits towards certification maintenance. The training, which included everything from Legal Aspects of Code Enforcement to Kitchen Exhaust Installations, was the center piece of the conference utilizing top trainers from around the country.

ICC CEO, James Lee Witt, former FEMA Director and ICC President Henry L. Green were on hand to install Officers and speak to the members. They spoke about the International Code Council Foundation that is helping the Gulf Region Code Officials that were devastated by the hurricanes last summer, get back on their feet. They also spoke regarding ICC's efforts to provide uniform codes for users nationwide. Mr. Witt is spearheading an effort called HEROS. It helps wounded war veterans retrofit their homes for handicapped accessibility as they return from war with devastating handicaps.

A table-top show, with manufacturers of building materials, computer systems and organizations such as ICC and UL were on hand to discuss their products and services. Several of the table-top vendors



also taught classes in their specialized areas. The ICC delivered a whole day class on the legal aspects of code enforcement which generated many questions from the class participants.

The social events were a big hit and well attended. On Saturday evening participants were treated to a buffet dinner and casino night at the Air and Space Museum, in Hampton. Everyone had a great time at the casino night and enjoyed the flight simulators. The next morning you had your choice of a golf outing or a fishing trip on the Chesapeake Bay. Although there weren't any hole in ones and very few fish were caught, everyone had a good time and took advantage of the opportunity to network.

Plans are being made for another joint conference in the future so be prepared to find yourself among the finest code enforcement officials in the state when we do it again.

*VPMIA's most recent progress and achievements are detailed in the President's message, page 6.*

# — Program —

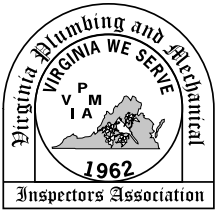

## VPMA 2008 School of Instruction

### Wednesday, April 9

- 7:00 - 8:30 a.m. **REGISTRATION**
- 8:30 - 10:00 a.m. **INTERNATIONAL MECHANICAL CODE 2006 (4 Hrs)  
AND INTERNATIONAL FUEL GAS CODE (2 Hrs)**
- 10:00 - 10:30 a.m. **BREAK**
- 10:30 - 12:00 p.m. **CLASS RESUMES**
- 12:00 - 1:00 p.m. **LUNCH**
- 1:00 - 2:30 p.m. **CLASS RESUMES**
- 2:30 - 3:00 p.m. **BREAK**
- 3:00 - 4:30 p.m. **CLASS RESUMES**
- 5:00 - 6:00 p.m. **PRESIDENT'S WELCOME**
- 6:00 - 7:30 p.m. **SOUTHERN BARBECUE**



### Thursday, April 10

- 8:30 - 10:00 a.m. **INTERNATIONAL PLUMBING CODE 2006 FUNDAMENTAL CLASS**
- 10:00 - 10:30 a.m. **BREAK**
- 10:30 - 12:00 p.m. **CLASS RESUMES**
- 12:00 - 12:15 p.m. **VPMIA GENERAL MEMBERSHIP MEETING - PART 1**
- 12:00 - 1:00 p.m. **LUNCH**
- 1:00 - 2:30 p.m. **CLASS RESUMES**
- 2:30 - 3:00 p.m. **BREAK**
- 3:00 - 4:30 p.m. **CLASS RESUMES**
- 6:30 - 10:00 p.m. **BANQUET—AWARDS**



### Friday, April 11

- 8:00 - 10:00 a.m. **GENERAL MEMBERSHIP MEETING - PART 2**
- 10:00 - 10:30 a.m. **BREAK**
- 10:30 - 12:00 p.m. **WELL & SEPTIC SYSTEMS**
- 12:00 - 1:00 p.m. **LUNCH WITH THE LADIES AUXILIARY**



**Be sure to visit the TABLETOP PRODUCTS SHOW.**  
**VPMA offers its gratitude to the following Tabletop Exhibitors:**

RMI, Inc  
Cast Iron Soil Pipe Institute

DuctMate  
NSF International

Sioux Chief  
Thermal Ceramics

## — Dedication —

VPMIA dedicates this Yearbook to **Jim Moore** for his dedicated service to the goals and mission of the organization. Jim has served selflessly for over 20 years by holding several different positions. These include: Plumbing Code Change Committee Chair, VPMIA BCAAC Representative for several years, Education Committee Chair, and served on the Virginia Regulatory Effectiveness Advisory Committee. Jim has also extended his services to other organizations: he has served as District Director and Regulatory Chairperson, and past President of the VCCCA. He was past BOCA representative on the CABO Plumbing Code Committee and member of the BOCA Code Interpretations Committee. Jim has always stepped up to the plate when asked to serve. He has been recognized for his participation in transforming the Virginia Building Code Academy's training from the traditional "reading sessions" to the current highly effective task-based, job-based training sessions they are today. His teaching experience was not only for the Code Academy, but also DHCD Code Update Training, Prince William Code Academy, Virginia Department of Health Backflow Prevention Schools, VPMIA, VCCCA, BOCA Annual Code Development and Educational Conference, PHCC, and PMPV of Virginia. His professionalism and hard work are good examples of why VPMIA is such a successful organization today.

# — 2007-8 VPMIA Resolutions —



## RESOLUTION

**WHEREAS;** That Guy Dupree Tomberlin, Sr. died on Wednesday, February 6, 2008, he was born on July 30, 1927,

**WHEREAS;** That Guy Tomberlin, Sr., is the Father of Active Member, Guy Tomberlin, Jr., a Past President of the Virginia Plumbing and Mechanical Inspectors Association (VPMIA) and remains an active Member of that Association,

**WHEREAS;** That Guy Tomberlin, Sr., served his beloved country During World War II in the United States Navy so serving for over thirteen years of active and reserve duty,

**WHEREAS;** That Guy Tomberlin, Sr., continued his career with Northwest Airlines at National Airport, Washington, D.C. and at the same time was a part time employee of A&P Food Stores for 25 years, and,

**WHEREAS;** That Guy Tomberlin, Sr., was a man with a caring heart, who enjoyed life and loved people; he lived his life with integrity and bravery. He was a member of the Kena Shrine and the Freemasons, both private fraternal associations for men, now therefore be it

**RESOLVED;** That the Officers, Board of Directors, and the entire Membership of the Virginia Plumbing and Mechanical Inspectors Association join Guy and his family in the celebration of his Father's life but also offer their most heartfelt sympathy at the loss of this cherished family member,

**RESOLVED;** That the Virginia Plumbing and Mechanical Inspectors Association stands in readiness to assist the family of Guy D. Tomberlin, Sr., in any manner desired or requested, and

**RESOLVED;** That this Resolution be published in the annual Virginia Plumbing and Mechanical Inspectors Association Newsletter as a permanent memorial to the memory of Guy D. Tomberlin, Sr.

Most sincerely submitted,

*Attest:*  
JOHN W. MILLS  
Vice President

*Approved:*  
DENNIS MARTINELLI  
President

## RESOLUTION



**WHEREAS;** Gerritt W. Fitzgerald passed away at home in Grass Lake, Michigan on January 17, 2008,

**WHEREAS;** That Gerritt W. Fitzgerald, is the Father-in-Law of Active Member, Ronald M. Bladen, Chairman, Yearbook and Advertising Committee and current Director, District 1 of the Virginia Plumbing and Mechanical Inspectors Association (VPMIA), and Father of Jane E. Fitzgerald (Bladen), current President, VPMIA Ladies Auxiliary, and

**WHEREAS;** That Gerritt W. Fitzgerald, served his beloved country as a B-17 pilot in the United States Army Air Corps, retiring as Captain, and

**WHEREAS;** That Gerritt W. Fitzgerald, served, originally with the U.S. Public Housing Administration and later as Senior Department Director for the U.S. Department of Housing and Urban Development, now therefore be it,

**RESOLVED;** That the Officers, Board of Directors, and entire Membership of the Virginia Plumbing and Mechanical Inspectors Association join Ron and his family in the celebration of his Father-in-law's life but also offer their most heartfelt sympathy at the loss of this cherished family member,

**RESOLVED;** That the Virginia Plumbing and Mechanical Inspectors Association stands in readiness to assist the family of Gerritt W. Fitzgerald, in any manner desired or requested, and

**RESOLVED;** That this Resolution be published in the annual Virginia Plumbing and Mechanical Inspectors Association Newsletter as a permanent memorial to the memory of Gerritt W. Fitzgerald.

Most sincerely submitted,

*Attest:*  
JOHN W. MILLS  
Vice President

*Approved:*  
DENNIS MARTINELLI  
President



## Virginia Plumbing & Mechanical Inspectors Association

### Foundation's Vision Statement

VPMIA members are committed to providing code development leadership and continuous training that results in uniform application of the codes. We look for opportunities to partner with all who are impacted and strive to develop and deliver codes and standards that result in health, safety, and welfare protection for the public.

### Mission

VPMIA is an association of code professionals dedicated to promotion of uniform enforcement and development of the codes throughout the Commonwealth to assure the health, safety, and welfare of its citizens and any one who may live, work, or visit the state of Virginia. The pursuit of this endeavor is achieved through close, open, and equal working relationships with design professionals, builders, contractors, material manufacturer's and others involved in the construction industry. VPMIA supports the ICC, its goals and mission.

### Strategic Plan Mission

VPMIA's strategic plan is to advance our mission through training in order to promote better understanding of the benefits and efficiency of using model codes. The association promotes teamwork, while embracing fairness and respect to all involved parties, always maintaining open communications in every aspect to those who participate in the process.

### CODE OF ETHICS

We the members of Virginia Plumbing and Mechanical Inspectors Association recognize that our work has a direct and vital impact on the quality of life for all people in the Commonwealth of Virginia, and we are dedicated to the highest standards of professionalism, integrity and competence. We therefore pledge to maintain and advance these ethical principles:

- Place the public safety and health above all other interests and recognize that the primary function of government is to service the best interests of all people.
- Consider my profession a distinct opportunity to serve society.
- Demonstrate integrity, honesty and fairness in the discharge of my duties by striving to achieve excellence in all matters of ethical conduct.
- Treat all persons courteously, equally and fairly.
- Conduct myself at all times in such a manner as to create and maintain respect for the Virginia Plumbing and Mechanical Inspectors Association and the industry it represents.
- Refuse to leverage my position to secure advantage of favor for myself, my family or my friends.
- Neither accept nor offer, any gift, favor or service that might tend to influence me in the discharge of my professional duties.
- Refrain from representing private interests in any business or technical affairs of this Association
- Use every opportunity to improve public understanding of the Virginia Plumbing and Mechanical Inspectors Association and its important contribution to the Commonwealth of Virginia.
- Maintain loyalty to the Virginia Plumbing and Mechanical Inspectors Association, and pursue its objectives in ways that are consistent with the public interest.

# — Constitution & By-Laws —

## VIRGINIA PLUMBING AND MECHANICAL INSPECTORS ASSOCIATION

### ARTICLE I — The Name, Seal, and Address of this Association

**Section 1.** The name shall be the Virginia Plumbing and Mechanical Inspectors' Association; herein and hereafter referred to as the Association.

**Section 2.** The seal shall be as indicated below:

**Section 3.** The address shall be that of the Executive Secretary or as otherwise designated by the Board of Directors.

### ARTICLE II — Objectives

**Section 1.** The objectives of the Association are:

- A. To participate in the formulation of Virginia Plumbing and Mechanical Code provisions.
- B. To promote uniform understanding and application of the Virginia Uniform Statewide Building Code.
- C. To promote and secure uniform inspection methods throughout the Commonwealth of Virginia.
- D. To promote closer industry unity between code officials, governing agencies and the private sector.
- E. To promote and improve the standard of professional plumbing and mechanical inspectors.
- F. To provide professional development through an annual education and training seminar which shall be known as the School of Instruction.
- G. To encourage growth of the Association by providing enhanced services to its members and by promoting strong leadership values, respect and the pursuit of common goals.

### ARTICLE III — Membership

**Section 1.** Active membership shall be open to code officials actively engaged in plumbing and/or mechanical code enforcement. Application for membership shall be in writing and submitted to the Executive Secretary.

**Section 2.** Associate membership shall be open to those persons interested in the design, manufacture, installation or sale of plumbing and/or mechanical systems and who are willing to promote the objectives of the Association. Application for membership shall be in writing, submitted to the Executive Secretary and reviewed by the Board of Directors for approval.

**Section 3.** Retired membership shall be open to those members submitting written application for retired status to the Executive Secretary.

**Section 4.** Life membership may be extended only to Active and Associate members who have significantly contributed to promoting the objectives of the Association. Life members may be nominated and approved by the general membership at the third general membership meeting. Life membership shall be limited to one Active member and one Associate member per calendar year.

**Section 5.** Charter members are those who founded the Association.

**Section 6.** Honorary membership shall be open to those persons who are not members of the Association but have made a significant contribution in promoting the objectives of the Association. Nominations for Honorary membership shall be in writing, submitted to the Executive Secretary by any member and reviewed by the Board of Directors for approval.

**Section 7.** All members shall conduct themselves in accordance with the Associations Code of Ethics.

### ARTICLE IV — Board of Directors

**Section 1.** The Association shall be governed by a Board of Directors, herein and hereafter referred to as the Board, which shall consist of the elected officers, District Directors Committee Chair Persons and the Director-at-Large.

**Section 2.** The Board shall manage the policies, business, property and affairs of the Association.

**Section 3.** Officers

- A. The officers of the Association shall consist of a President, Vice President, Secretary and Treasurer. The officers shall be Active members and shall be elected and installed during the annual School of Instruction.
- B. The officers shall hold office from the close of the annual School of Instruction through the close of the annual School of Instruction of the following year. Officers shall serve no more than two consecutive terms in the same office.

**Section 4.** Directors

- A. A total of eight Active members may be elected as District Directors. The Directors shall be Active members and shall be elected and installed during the annual School of Instruction.
- B. The Directors shall hold office from the close of the annual School of Instruction through the close of the annual School of Instruction the following year.
- C. Each District shall consist of all cities, towns and counties as outlined in Appendix A.
- D. The Director-at-Large shall be the immediate Past President.
- E. Non-voting Ex-officio members on the Board of Directors shall include the President, or his or her duly appointed representative, of the Virginia Chapter of the International Association of Electrical Inspectors, The Virginia Fire Prevention Association, and The Virginia Building Code Officials Association.

**Section 5.** In the event that an Officer or Director resigns, the Board shall appoint, as soon as possible, an Active member to fill the unexpired term.

**Section 6.** Appointments



- A. An Executive Secretary shall be appointed by the Board for a maximum term of five years or as determined by the Board. Compensation of services rendered shall be as approved by the Board.
- B. A Director of Finance shall be appointed by the Board for a maximum term of five years or as determined by the Board. Compensation of services rendered shall be as approved by the Board.

**ARTICLE V — Duties of the Officers, Directors, Executive Secretary and Finance Director**

**Section 1. The President**

- A. To preside over all meetings.
- B. To select all committee chairpersons except the finance and the nominating committees.
- C. The President may appoint members to represent the Association on local, state or national committees, boards and similar entities when such representation is requested or provided for by regulation or statute. Appointments shall not conflict with the Association's By-laws or code of ethics.
- D. To be an ex-officio member of all committees except the nominating committee.
- E. To perform such other duties applicable to the office as prescribed by the parliamentary authority adopted by the Association.

**Section 2. The Vice President**

- A. To assist the President at all meetings.
- B. To preside over all meetings in the absence of the President.
- C. To perform such other duties as applicable to the office as prescribed by the parliamentary authority adopted by the Association.

**Section 3. The Secretary**

- A. To assist the presiding officer with the orders of business and to distribute correspondences to all members present.
- B. Notification of meetings.
  - 1. To send to all Board members a notice of every Board meeting at least twenty days in advance of such meeting
    - a. Ten days notice, including an agenda, shall be given for all special meetings.
  - 2. To send all members a notice of every General Membership meeting at least thirty days in advance of such meeting.
- C. To accurately record all business transacted at all meetings.
- D. To maintain and have available at all meetings the

official minute book.

- E. To record the voting at all meetings.
- F. To send letter ballots to all Board members not present at meetings for which there is no quorum.
- G. To perform such other duties as applicable to the office as prescribed by the parliamentary authority adopted by the Association.

**Section 4. The Treasurer**

- A. To accurately record and post all funds received and disbursed. Shall be bonded for at least fifty thousand dollars. The bond premium shall be paid by the Association.
- B. To pay all bills that have been approved as per the budget or by the Board.
- C. To submit a quarterly report of the Association's finances to the Finance Committee.
- D. To submit a report of the Association's finances at all meetings, except special meetings unless included in the special meeting agenda.
- E. To send all membership renewals by December 1 of each year.
- F. To maintain the financial records of the Association on a fiscal year from May 1 through April 30, unless otherwise approved by the Board.
- G. To be a standing member of the Finance Committee.
- H. To perform such other duties as applicable to the office as prescribed by the parliamentary authority adopted by the Association.

**Section 5. The District Director**

- A. To attend at least two Board meetings per term of office.
- B. To assist in the management of the Association.
- C. To report any concerns of the members within their district to the Board.

**Section 6. The Executive Secretary**

- A. To prepare for the Board all business that has not been assigned to others.
- B. To present or have presented at all meetings all reports received from committee chairpersons.
- C. To recommend plans of work and conduct the general business of the Association under the direction of the Board and the General Membership.
- D. To be a standing member of the School of Instruction Committee.
- E. To authorize both active and/or retired membership status.

*Art. V, continued*

*Art. V, continued*

- F. To maintain all membership applications.
- G. To receive the letter of resignation of an Officer or Director and present it at the next Board meeting.
- H. To send to each Director a current roster of all members within their respective districts no more than thirty days after the third General Membership meeting.
- I. To maintain and have available at all meetings a current roster which lists only members in good standing by district affiliation.

**Section 7.** The Director of Finance

- A. To coordinate the finances of the Association.
- B. To serve as the chairperson of the Finance Committee.

**ARTICLE VI — Committees**

**Section 1.** The number of committee members, mentioned below, includes the chairperson. Committee chairpersons are appointed by the President, see previously in the text, Article V,

**Section 1.B.** Committee members are selected by the committee chairperson as stated hereinafter in this Article or are established within the description of the committee. Committee members that are established by the text are in addition to those members appointed and selected. Committees may include, but not limited to. The following:

**Section 2.** An Advertising and Yearbook Committee, composed of five members, shall be appointed within thirty days after the third General Membership meeting. It shall be the duty of this committee to manage an advertising campaign and publish the yearbook for the Association's School of Instruction.

**Section 3.** An Auditing Committee, composed of three members, shall be appointed within thirty days after the third General Membership meeting. It shall be the duty of this committee to audit the Treasurer's account(s) at the close of the calendar year and report at the fourth regular Board meeting. The Treasurer shall not be a member of this committee.

**Section 4.** An Awards Committee, composed of five members, shall be appointed within thirty days after the third General Membership meeting. It shall be the duty of this committee to select and present, the awards for Outstanding Service to the Active and Associate members of the Association and the awards to the individuals that are the outstanding plumbing and mechanical apprentice of the year.

**Section 5.** A By-laws Committee, composed of five members, shall be appointed within thirty days after the third General Membership meeting. It shall be the duty of this committee to review, discuss, prepare and recommend, to the Association, any necessary changes to the Association's By-laws in order to maintain current directives for the administration of the Association.

**Section 6.** A Certification, Education, and Training Committee, composed of five members, shall be appointed within thirty days after the third General Membership meeting. It shall be the duty of this committee to organize educational classes for the School of Instruction.

**Section 7.** A Finance Committee, composed of three members, the Treasurer and the Finance Director, shall be appointed within thirty days after the third General membership meeting. It shall be the duty of this committee to prepare a budget for the fiscal year and submit it to the Board for approval at its last scheduled meeting prior to the third

General Membership meeting. The committee may submit amendments to the current budget at any regular meeting. The committee shall prepare and submit any other reports as directed by the Board.

**Section 8.** A Legislative Committee, composed of three members, shall be appointed within thirty days after the third General Membership meeting. It shall be the duty of this committee to attend as many Virginia General Assembly meetings as possible and to be observant of new regulations. This committee will review, discuss and report to the Board of Directors and the General Membership, any legislature or regulations that will directly or indirectly effect the Association or its members.

**Section 9.** A Mechanical & Fuel Gas Code Committee, composed of all Association members willing to participate, the chairperson shall be appointed within thirty days after the third General Membership meeting. It shall be the duty of this committee to review, discuss and recommend necessary changes that apply to the Mechanical Code and the Fuel Gas Code.

**Section 10.** A Membership and Website Committee, composed of five members, shall be appointed within thirty days after the third General Membership meeting. It shall be the duty of this committee to keep the website current and updated. The website shall be the source of Association meetings, dates, membership and advertisement applications, Association and public information and other Association information.

**Section 11.** A Nominating Committee shall be composed of the five most immediate past presidents of the Association willing to serve in this capacity. The most immediate past president on the committee shall serve as the chairperson. It shall be the duty of this committee to nominate, at the third General Membership meeting, candidates for the offices to be filled. Before the election, additional nominations from the floor shall be permitted.

**Section 12.** A Plumbing Code Committee, composed of all Association members willing to participate, the chairperson shall be appointed within thirty days after the third General Membership meeting. It shall be the duty of this committee to review, discuss and recommend necessary changes that apply to the Plumbing Code.

**Section 13.** A School of Instruction Committee, composed of three members, the Executive Secretary, the chairpersons of the Time and Place Committee and the Certification, Education and Training Committee, shall be appointed within thirty days after the third General Membership meeting. It shall be the duty of this committee to plan the program for the next Annual School of Instruction.

**Section 14.** A Special Committee, composed of five members, shall be appointed for a specific purpose, when necessary. It shall be the duty of this committee to carry out a specified task and present a report to the Board.

**Section 15.** A Time and Place Committee, composed of five members, shall be appointed within thirds after the third General Membership meeting. It shall be the duty of this committee to review the date and location of all General Membership meetings and submit a report and recommendation to the General membership for approval at least twelve months prior to such meeting.

**Section 16.** Committees shall be under the authority and direction of the Board, unless specifically provided for herein.

**Section 17.** Duties of the Committee Chairperson

- A. To submit, in writing, all committee findings and recommendations to the Executive Secretary at least ten days prior to any meeting, except special meetings, unless specified on the agenda. If the



chairperson or members of the committee is in attendance at the meeting, such written report shall not be required.

- B. To select all committee members not specifically provided for in other sections of these by-laws and report their names to the Executive Secretary within thirty days of their appointment.

#### ARTICLE VII — Voting

**Section 1.** Only Active, Charter and Lifetime Active members who are in good standing shall have the right to vote.

**Section 2.** All members shall have the right to make and second motions.

#### ARTICLE VIII — Meetings

**Section 1.** Three General Membership meetings shall be held each year. The first shall take place approximately fourteen days prior to or fourteen days after August 1. The second shall take place approximately thirty days prior to or thirty days after November 15. The third shall take place approximately fourteen days prior to or fourteen days after April 1, during the Annual School of Instruction.

**Section 2.** Four Board meetings shall be held each year at a time and location determined by the President. The first shall be held at least sixty days prior to the first General Membership meeting. The second shall be held at least sixty days prior to the second General Membership meeting. The third on the day of the second General Membership meeting and the fourth at least thirty days prior to the third General Membership meeting. A quorum shall consist of at least seven Board members. Action taken by less than seven Board members shall be null and void unless confirmed by a letter ballot from those members who were absent.

**Section 3.** Special Board meetings may be called by the President. Such meetings may also be called by the Board with the written request of at least seven members. The purpose of the meeting shall be stated in the call. The location of the meeting shall be determined by the President. At least ten days notice shall be given. A quorum shall consist of at least ten Board members. Action taken by less than ten Board members shall be null and void unless confirmed by a letter ballot from those members who were absent.

#### ARTICLE IX — Dues

**Section 1.** Annual Dues

- A. Active membership shall be thirty dollars per calendar year.
- B. Associate membership shall be thirty-five dollars per calendar year except those who have paid for five consecutive years shall only be required to pay thirty dollars per consecutive calendar year thereafter.
- C. Retired membership shall be ten dollars per calendar year.
- D. Charter and Life membership shall be absorbed by the Association.

**Section 2.** No members shall be in good standing whose dues are not paid by March 1 of each year and shall not be maintained on the

membership roster if not paid by December 31.

**Section 3.** Dues may only be revised at General Membership meetings.

# — Ladies Auxiliary —

Ladies,  
You are invited to join us—our activities are  
**OPEN TO ALL SPOUSES ATTENDING THIS  
CONFERENCE**

Why not become an Auxiliary member?  
Annual Dues \$10 — payable at registration

## 2008 Program Schedule

### Wednesday, April 9

7:00 – 8:30 a.m.	REGISTRATION (Ladies Auxiliary)	Lobby
11:00 – 2:00 p.m.	Kluge Art Museum tour and LUNCH out (informal)	Meet in Lobby
2:00 – 4:30 p.m.	Craft or Bingo	Hospitality Room
5:00 – 6:00 p.m.	PRESIDENT'S WELCOME	Banquet Room
6:00 – 7:30 p.m.	Bar B Q Dinner	Banquet Room

### Thursday, April 10

7:30 – 9:00 a.m.	REGISTRATION	Lobby
9:00 – 11:30 a.m.	CRAFT	Hospitality Room
11:30 – 1:30 p.m.	LUNCHEON and BUSINESS MEETING	Meet in Lobby Local Restaurant
1:30 – 4:30 p.m.	SHOPPING	
6:00 – 10:00 p.m.	BANQUET, AWARDS, INSTALLATION OF OFFICERS	Banquet Room

### Friday, April 11

7:30 – 8:30 a.m.	REGISTRATION	Lobby
9:00 – 11:30 a.m.	BINGO	Hospitality Room
12:00 – 1:00 p.m.	LUNCH VPMIA & Ladies	Banquet Room

The VPMIA Ladies Auxiliary is an ancillary group to VPMIA. Its purpose is to act as an assistant and a support to the Association's endeavors to provide code development leadership and continuous training that results in uniform application of the codes.

This group is also about having fun along the way.

Join us in Charlottesville. We will conduct our annual luncheon/business meeting and get to know each other better during some scheduled events: exploring items of local interest, some friendly games of Bingo and a craft activity. These informal activities are scheduled to take place while the VPMIA meetings and School of Instruction are in session—leaving time to socialize with the full VPMIA group during lunches and dinners.

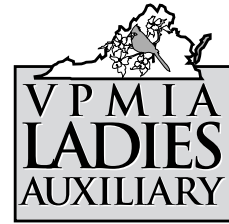

## Membership Roster as of March 2008

Jane Fitzgerald (President)  
VPMIA (Ron Bladen)  
5716 North 7th Street  
Arlington, VA 22205  
703-527-4210 (H)  
703-527-1238 (W)  
msfitz13@verizon.net

Mary Thuot (Vice President)  
VPMIA (Michael)  
3197 Adam Keeling Road  
Virginia Beach Va 23454  
757-496-0355.  
mthuot2686@aol.com

June Seay (Secretary/Treasurer)  
VPMIA (John)  
280 Coles Rolling Road  
Scottsville, VA 24590  
434-286-3139  
jws5z@virginia.edu  
seayit2@yahoo.com

Connie Hines  
VPMIA (Bill)  
4086 Stanberry Avenue  
Marshall, VA 20115  
540-364-2934

Sherry D. Rimel  
VPMIA (Paul)  
1159 New Hope Road  
Staunton, VA 24401  
540-248-6627 (H)  
540-332-7086 (W)  
rimelsd@comcast.net

Ethel Showman  
(Past President)  
VPMIA (Geary)  
1221 St. Luke Road  
Woodstock, VA 22664  
540-459-2789  
eshowman@shentel.net

Sandy Tomberlin  
VPMIA (Guy)  
1358 Ebenezer Road  
Bluemont, VA 20135  
540-554-2765 (H)  
703-324-1817 (W)  
sandytomberlin@msn.com



# L.A. Lacy, Inc.

*Commercial and Industrial Design Build Mechanical Contractor*  
Celebrating 85 years of Quality!  
[www.lalacy.com](http://www.lalacy.com)

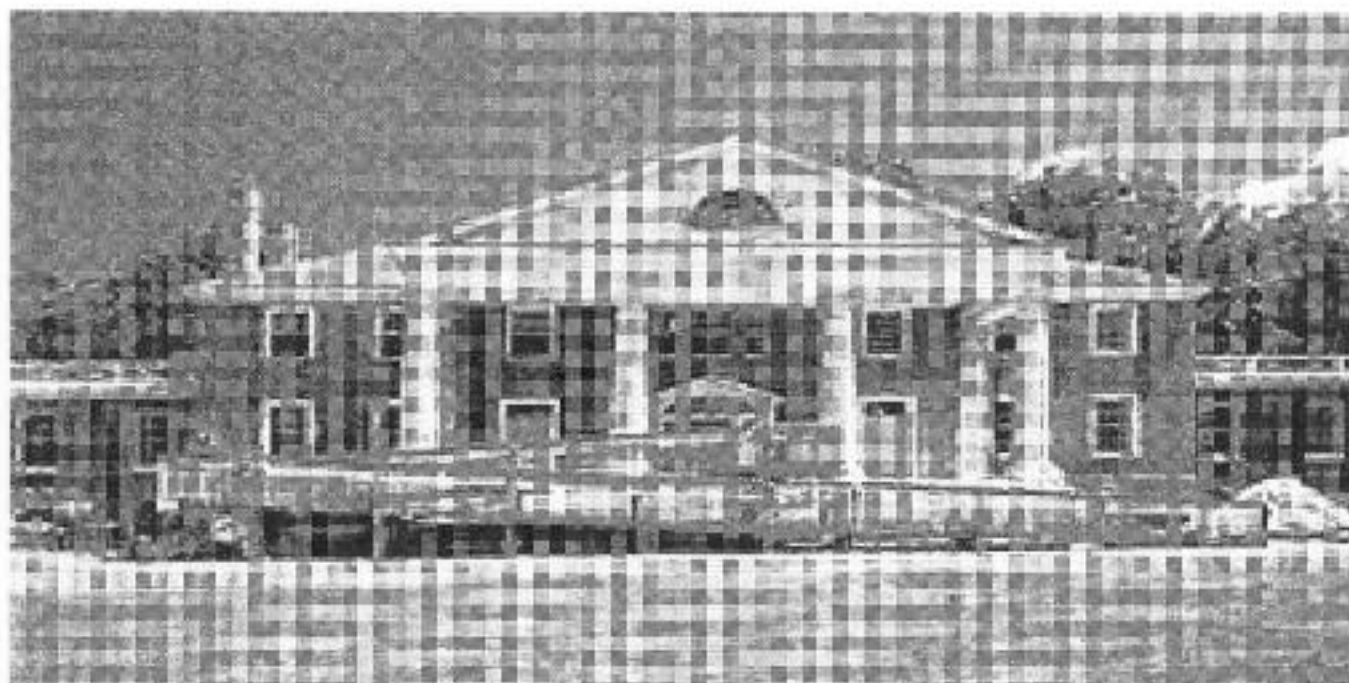

Proud participant in the James Madison Montpelier Restoration Project

900 Harris Street  
Charlottesville, VA 22903

Phone: 434.296.7542  
Fax: 434.293.9073



# VPMIA Awards Roster

## OUTSTANDING SERVICE

### Gordon I. Dameron Active Award

1981-1982	Kenneth R. Synder, Jr.
1982-1983	Jesse R. Hurt
1983-1984	George H. Williams, Jr.
1984-1985	Robert M. Broome
1986-1987	Paul M. Adams
1988-1989	Paul Hostetler Joseph Hall
1989-1990	Dennis W. McNaughton
1990-1991	Floyd Proffitt
1991-1992	Jeffrey Shawver
1992-1993	Tommy Cantrell
1993-1994	Hassel E. DeShazo
1994-1995	Doug Stover Jack Rhoden
1995-1996	Robert D. Carroll
1996-1997	Roy N. McFarland, Jr.
1997-1998	Kathleen T. Dye
1998-1999	_____
1999-2000	Michael D. Thuot
2000-2001	Guy Tomberlin
2001-2002	John B. Seay, Jr.
2002-2003	Dennis Martinelli
2003-2004	Geary Showman
2005-2006	Wayne Kushner

### David L. Carr Associate Award

1981-1982	William E. Foley
1982-1983	John V. Duley
1983-1984	J. C. Nuckols
1984-1985	Lawrence R. Muse
1986-1987	David Maupin
1987-1988	Ronald Bryant
1988-1989	Robert W. Price
1989-1990	Fred Borden, Jr.
1990-1991	Billy E. Leeder
1992-1993	James B. Muncy
1993-1994	John Otto
1994-1995	Danny & Laurie Crigler
1995-1996	James B. Hylar
1996-1997	J. C. Nuckols
1997-1998	James S. Steinle
1998-1999	Thomas C. Roberts
1999-2000	David Johnston
2000-2001	David L. Maupin
2001-2002	Lorrie Norton
2002-2003	Allen Tryall
2003-2004	Jonathan Sargeant
2005-2006	David Maupin



## VPMIA Past Presidents

CHARLES E. MANNION	1963*
PAUL C. KING	1964*
GORDON I. DAMERON	1965*
D. PAUL JACK	1966*
FRANK B. BOSMA	1967
U. EARL ALLEN	1968*
HARRY CONTE	1969
JAMES B. JONES	1970*
L. W. FURMAN	1971
GEORGE H. WILLIAMS	1972*
W. T. DRAKE	1973*
BENJAMIN BIANCO	1974
J. L. SHIFFLETT	1975
HOMER O. DENNIS	1976
JULIAN E. MEREDITH	1977
EDWARD T. PARSONS	1978*
EDWARD J. BALDWIN, JR.	1979
HENRY A. RODÉS	1980*
RUDOLF SCHROECK	1981
JESSE R. HURT	1982
CHARLES DEDIAN	1983
KENNETH R. SNYDER, SR.	1984
LAWRENCE J. NUCKOLS	1985
JOHN W. THURSTON	1986*
WILLIAM F. HINES	1987
LESLIE A. COURTNEY	1988
JIMMY A. ENGLISH	1989
DOUGLAS L. STOVER	1990
ROBERT M. BROOME	1991
PAUL D. HOSTETLER	1992
DENNIS W. McNAUGHTON	1993
JOHN S. TRENARY	1994
MICHAEL D. REDIFER	1995/1996
KATHLEEN T. DYE	1997
HASSEL DeSHAZO	1998
ROY N. McFARLAND, JR.	1999/2000
CLEATIS DYE, JR.	2001
CHARLES GERBER	2002
GUY TOMBERLIN	2003/2004
GEARY SHOWMAN	2005
MICHAEL THUOT	2006
JOHN SEAY	2007

\*Denotes deceased

## LIFETIME MEMBERSHIP

### D. Paul Jack Active Award

1988-1989	Edward J. Baldwin, Jr.
1989-1990	George H. Williams, Jr.
1990-1991	Kenneth R. Snyder, Jr.
1991-1992	Jesse R. Hurt
1992-1993	Douglas Stover
1993-1994	Ernest "Bud" Lester
1994-1995	Paul Hostetler
1995-1996	Paul M. Adams
1996-1997	Michael D. Redifer
1997-1998	Hassel E. DeShazo
1998-1999	Kathleen T. Dye
1999-2000	_____
2000-2001	William F. Hines
2001-2002	Larry Dehaven
2002-2003	Lawrence Nuckols
2003-2004	Roy McFarland, Jr.
2004-2005	Guy Tomberlin
2005-2006	Stephen P. Borders

### John A. Otto Associate Award

1988-1989	Cecil F. Hardee, Sr.
1989-1990	J. Richard Maher
1990-1991	David L. Carr
1991-1992	Robert W. Price
1992-1993	_____
1993-1994	Billy E. Leeder
1994-1995	James B. Muncy
1995-1996	Thomas C. Roberts
1996-1997	Tom Kreutzer
1997-1998	James S. Steinle
1998-1999	John Otto
1999-2000	_____
2000-2001	Herbert L. Joyner
2001-2002	Laurie/Danny Crigler
2002-2003	Dave Johnson
2003-2004	_____
2004-2005	_____
2005-2006	_____

# Bright futures for skilled craftsmen

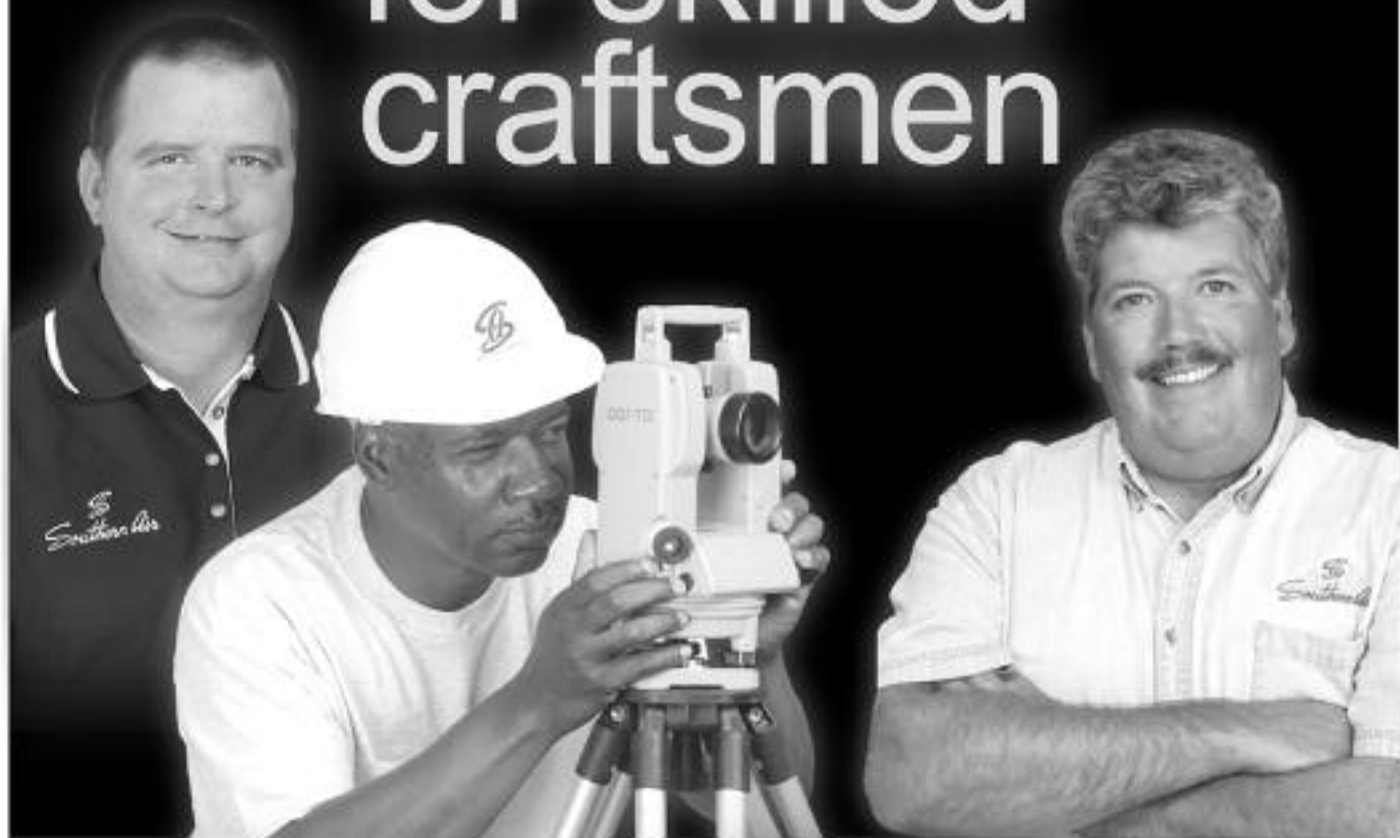

*Southern Air*

Electrical • Plumbing • HVAC

800/743-1214

Quality Sales & Service  
Since 1924

Virginia Registration  
#2701005193A



**SERVICE TODAY**  
**W. E. Brown, Inc.**

*Plumbing - Heating - Air Conditioning - Electrical*  
915 Monticello Road • Charlottesville, VA 22902  
**24 Hour Emergency Service**

**Dave Maupin**  
(434) 951-8712  
dave@webrown.com

PH (434) 295-1177  
FAX (434) 979-1394  
1-800-W E Brown

—From Ron Bladen, Chairman—  
VPMIA Advertising/Yearbook Committee

**Thank You**  
*to the 2008 VPMIA YEARBOOK Contributors*

Dennis Martinelli  
President, VPMIA

Jane Fitzgerald  
Fitzgerald Art & Design LLC

John Seay  
Past President, VPMIA

Don Bladen  
VMW Printing

Gearry Showman  
Executive Secretary, VPMIA

Our Advertisers  
Individually listed on page 5

**with special thanks to**  
*Jay Peters and Lee Clifton, International Code Council, and  
Wes Davis, Air Conditioning Contractors of America*

# — Strategic Plan —

## **GOAL # 1**

### **— Enhance and increase communications of VPMIA with the public (Communications)**

#### *Initiative action:*

- Actively promote a positive image of code enforcement's role in the community.
- Advertisements in trade, industry, state DHCD, and community publications.
- Commitment to code development to achieve the superior level of health, safety, and welfare for our citizens.

## **GOAL # 2**

### **— Increase and expand education (Training — Communications)**

#### *Initiative action:*

- Encourage increased participation from all interested parties who interact with any and all aspects of code enforcement.
- Increase awareness of the educational benefits of the association.
- Promote credentialing programs provided by the state DHCD.

## **GOAL # 3**

### **— Uphold the highest levels of professionalism (Leadership — Professionalism)**

#### *Initiative action:*

- Instill and promote leadership values.
- Always display integrity.
- Adherence to code of ethics.
- Share knowledge at all levels.
- Maintain and promote certifications.
- Respect others.

## **GOAL # 4**

### **— Promote relationships with industry and related professional organizations (Cooperation)**

#### *Initiative action:*

- Participate in the code development process.
- Encourage cooperative working relationships with construction-industry professionals.
- Become involved as active or associate members to other professional organizations such as VBCOA, ICC, VCCCA, IA EI, and PMPV.
- Solicit speakers and provide speakers for these organizations to enhance communication.
- Continue to actively participate in DHCD towards uniform application and development of the model building codes and standards.

## **GOAL # 5**

### **— Broaden and expand VPMIA Membership (Membership)**

#### *Initiative action:*

- Develop information package of the organization benefits.
- Provide more member services.
- Develop a more wide spread advertisement program for membership, including associate members.

## **GOAL # 6**

### **— Continue leadership and participation in code development process (Leadership — Code Development)**

#### *Initiative action:*

- Enhance and develop strategies for participation in International Code Council Code developmental process.
- Encourage participation on state and national committees.
- Provide financial support towards member participation in these activities.

## **GOAL # 7**

### **— Promote the adoption of the International Code Council family of model codes (Communications — Training)**

#### *Initiative action:*

- Provide analysis and impact of benefits for industry, where necessary.
- Provide training for code enforcement officials and industry.
- Interact with DHCD to provide uniform enforcement of model codes.

## **GOAL # 8**

### **— Ensuring financial viability of VPMIA**

#### *Initiative action:*

- Align financial resources to organizational outcomes.
- Achieve goal objectives.
- Operate within budgeted plan.

## — Upcoming Events —



### Summer School of Instruction

**Thursday and Friday  
August 7-8, 2008  
Graves Mountain Lodge**

**Training, Meeting and Picnic**

**YOU can participate in VPMIA**  
throughout the year.

Attend Board of Directors Meetings (4 meetings) and General Membership meetings (3 meetings) throughout the year, check for the most current times and location information on the VPMIA web site at [www.vpmia.org](http://www.vpmia.org)



# Be part of the 2008 JOINT CONFERENCE

VPMIA and VBOCA have finalized plans for a Joint Conference to be held October 26-29, 2008 in Wytheville, VA.

Additional details will be available soon. Check either association website for updates and other information.





*Some leaks are beautiful, as they are;  
for the rest, call...*

**the plumbing dr**



Fully licensed, bonded and insured — 24 hour emergency service

*Complete Plumbing Repairs  
Remodeling, Sewer & Drain Cleaning*

*Family Owned and Operated for over 25 Years*

**The Plumbing Dr.** has been honored by **Washingtonian Magazine** and **Consumer Checkbook** as one of the top-rated plumbing services in the region.

1063-B W. Broad Street • Falls Church, VA 22046  
Phone: 703.525.9280 • [www.theplumbingdr.com](http://www.theplumbingdr.com)

# WARDFLEX™ CSST

When choosing a CSST system for natural gas or propane...  
 Choose experience. Choose **WARDFLEX™**  
 The **ONLY CSST with a LIFETIME WARRANTY...!**



**Elkhart Products Corporation**

[www.elkhartproducts.com](http://www.elkhartproducts.com)

## QTITE™

**WORK QUICK. WORK SMART.**

A permanent Wrot Copper Push-to-Connect System for Copper, CPVC & PEX



## TECTITE™

A Removable Brass Push-to-Connect System for Copper, CPVC & PEX - **NOW UP TO 2"**



## XPRESS™

**THE FASTER FIT.**

Simple, clean, efficient joining method that improves the joining process & speeds up installation  
**SAVING SIGNIFICANT TIME & MONEY.**



## MODINE | APPLIED THERMAL INNOVATION™



Modine is the leader in design, engineering & manufacturing of heating, ventilating & air-conditioning equipment. We provide unit, infrared and cabinet heaters and fin-tube radiators for commercial, agricultural & industrial markets. Looking for the perfect solution for heating up your garage, workshop or greenhouse? Then check out our low-profile **HOT DAWG®**.

Represented by...  **Harry Eklof & Associates, Inc.**

3401 Pennsy Drive • Landover, MD 20785 • 800-556-7556 • 301-772-1700 • Fax 301-772-7347  
[www.harryeklof.com](http://www.harryeklof.com) E-mail: [info@harryeklof.com](mailto:info@harryeklof.com)

# The International Plumbing Code

# Protecting the Environment

**Lee Clifton**

Director of Plumbing Programs  
Plumbing, Mechanical and Fuel Gas (PMG)  
International Code Council

The Environmental Protection Agency (EPA) estimates that there are over 40,000 sanitary sewer overflows each year — the majority caused by grease buildup. Maintaining these sewers is costly - more than \$25 billion per year — a situation exacerbated by attendant cleanup fines levied by the EPA and/or the Authority Having Jurisdiction.

The 2006 IPC specifies that grease interceptors and automatic grease removal devices shall conform to PDI G101, ASME A112.14.3 or ASME A112.14.4 and be installed in accordance with the manufacturers' instructions. ICC Evaluation Service, Inc., which operates under the umbrella of the International Code Council, certifies these devices to the aforementioned standards.

The purpose of grease interceptors is to reduce the amounts of fat, oil, and grease (FOG) in waste water to acceptable levels in conformance with the IPC. Eating establishments, hospitals, hotels, convention centers, sports arenas, prisons, etc., generate huge amounts of FOG each year which they allow to enter

the waste water system, the grease readily adhering to the inner surface of piping materials. This becomes a primary cause for clogs, backups, overflows, and equipment failure as the accrued layers harden into crust as tough as baked clay, leading to a need for the replacement of the affected pipes.

The recent changes in the IPC on grease interceptor installation requirements are a result of the need to address these issues.

The definition Flow Control (Vented) has been added to define the device that is used on hydromechanical grease interceptors, formerly called grease traps. This new definition now clarifies the flow control device referenced and explained in Section 1003.3.4.2. This section of the IPC specifies that grease interceptors shall be equipped with devices that control the rate of water flow so it doesn't exceed the rated flow of the interceptor. This device must be vented and terminate at least 6 inches above the flood rim level or be installed in accordance with the manufacturer's instructions.

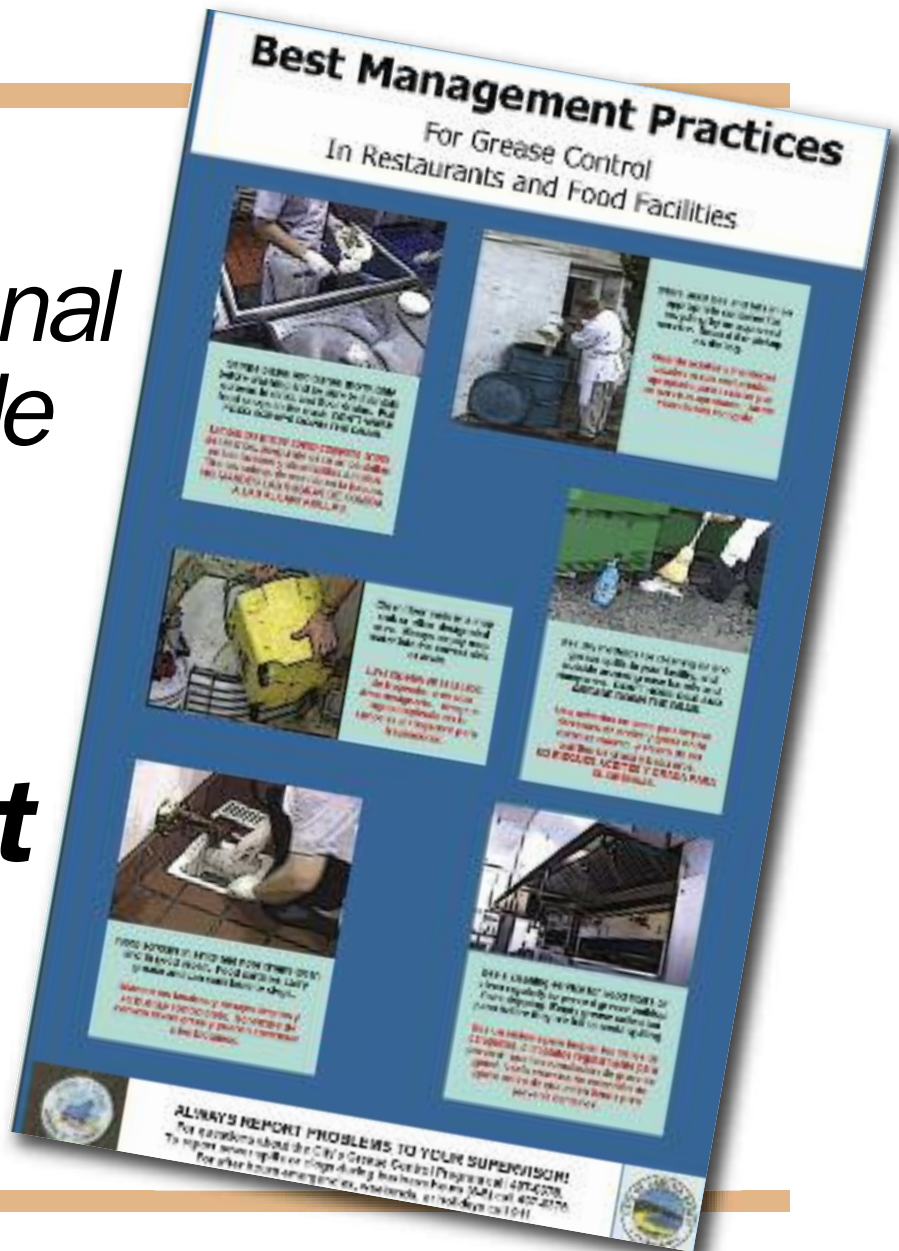

## General Drainage Requirements for a Food Establishment

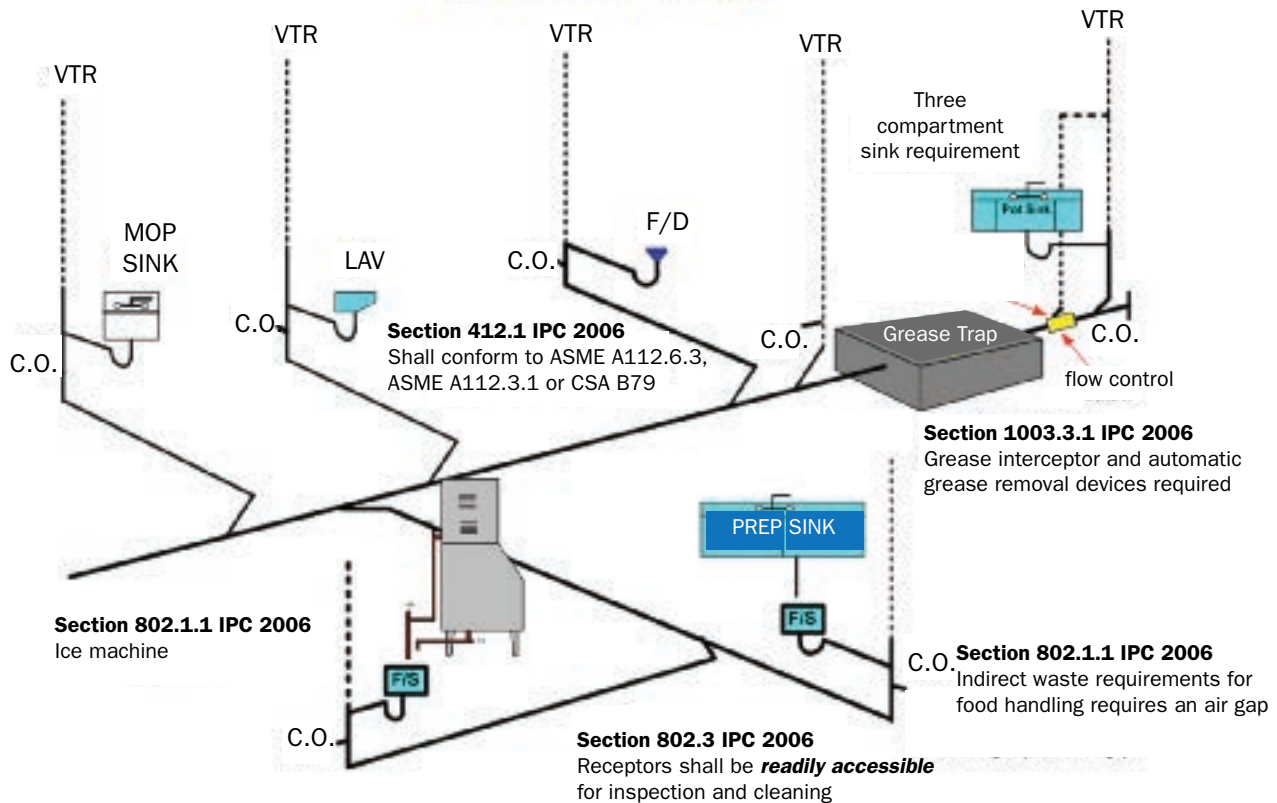

Also, a pair of additional flow rates and capacities has been added to Table 1003.3.4.1 in the IPC: “The modification to the table is in accordance with ASME A112.14.3 for standard flow rates and grease retention capacity ratings for grease interceptors.”

Grease retention capacity must be based on the flow-through rating of the grease interceptor and the discharge rate of the drainage pipe served. The waste flow capacity of a grease interceptor determines the quantity of grease that can be separated from the waste, which in turn, dictates the required capacity of the grease interceptor to hold the collected grease. The maintenance frequency for a grease interceptor is directly proportional to the retention capacity of the device.

Grease control devices must be cleaned or maintained regularly in order to function properly. Most agencies consider the requirement to install grease control devices to be the most important part of their fat, oil, and grease (FOG) control program. The general thinking is that even if kitchen Best Management Practices (BMP) is not fully implemented, the grease control device(s) will capture the grease and protect the sewer. However, some agencies are requiring mandatory monthly cleaning of conventional grease interceptors or daily cleaning or

maintenance of grease removal devices.

In closing, a combined effort from restaurant employees, code officials, sanitation districts, and industry working together will be what makes the difference. The City of Virginia Beach has undertaken a public outreach program in order to help eliminate fat, oil, and grease (FOG) from their sewers. A proposed ordinance is currently being reviewed by the city council. Virginia is also currently the home of several biodiesel refineries. Three produce biodiesel from soy and a few others produce biodiesel from waste grease and oils. ■

Lee Clifton is the Director of Plumbing Programs for the International Code Council, Plumbing, Mechanical & Fuel Gas (PMG). Prior to joining the Code Council, Lee was with the City of Los Angeles for 21 years. As the Principal Inspector with the City of Los Angeles this included planning, organizing and coordinating the training programs for approximately 200 inspectors and clerical staff that work for the Housing Department. Lee currently serves on the Board of Directors for the Southern California Health and Housing Council. And participating on the Strategic Planning Committee to end lead poisoning in Los Angeles County. In prior years Lee also served as a Senior Plumbing Training Officer for the Department of Building and Safety and has taught model plumbing code for the Plumbing, Heating, Cooling, Contractor Association of the Greater Los Angeles Area and the North Orange County Regional Occupation Program over the past 20 years.

**Ready for a quality home?**



**New Shelter Construction, Inc.**

**3714 Mountain Road**

**Haymarket, VA 20169**

**703-754-7196**

**Contact Jeff Heflin, Owner**

**Custom Framed Homes • Log Homes • Additions**

**Full line of doors and windows, specializing in Andersen.**



# Reviewing HVAC Designs

by Wes Davis

**B**uilding officials routinely require heating, ventilation and air conditioning (HVAC) system design information as part of the permitting process for commercial buildings, but some hesitate to request the same information for residential HVAC systems. As a reminder, the 2006 International Residential Code (IRC) requires the following.

- Section 1401.3: “Heating and cooling equipment shall be sized based on building loads calculated in accordance with ACCA [Air Conditioning Contractors of America] Manual J or other approved heating and cooling calculation methodologies.”
- Section 1601.1: “Duct systems serving heating, cooling and ventilation equipment shall be fabricated in accordance with the provisions of this section and ACCA Manual D or other approved methods.”

From my experience, building officials do not require HVAC design information because they think it would take too long to properly review the load calculation and duct design, they may be concerned that they do not know what to look for and would not know how to address a contractor’s challenges, or they may believe that air conditioning does not present a health or safety issue. The fact is that HVAC design or installation problems can affect a home’s structural integrity and affect occupants’ safety and health.

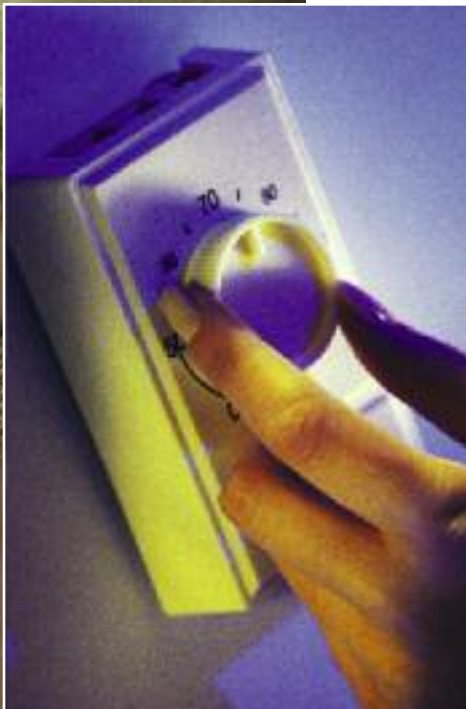

Reprinted from the March 2008 edition of *Building Safety Journal*, copyright 2008 the International Code Council.

Comfort cooling has become standard equipment for most homes built today, and the building codes require that these systems be properly designed. Code officials are charged with enforcing this requirement and should therefore review the load calculation and duct design.

## Load Calculation

If identical homes are built in Boston and Phoenix, the one in Boston will use more heating and the one in Phoenix will use more cooling. This may seem like an obvious consideration, but some HVAC system designers will use Phoenix’s summer temperature to determine the cooling needs for the Boston home and Boston’s winter temperature for the Phoenix home. They may seek to justify this by recalling a scorching Massachusetts summer and a long Arizona winter. However, rather than relying on isolated historic or anecdotal examples, building officials should make use of the high and low design temperature data that has been developed by scientific and engineering groups to 99 percent accuracy.<sup>1</sup>

For example, ACCA Manual J, Table 1A, gives the summer design temperature for Ft. Meyers, Florida, as 93°F. There will be some scorching July afternoons when the temperature rises even higher, but from year to year this will only occur 1 percent of the time. Meanwhile, the winter design temperature for Ames, Iowa, is -6°F. There will be some bone-chilling January nights when

the mercury drops even further, but 99 percent of the year the weather will be warmer. Thanks to such highly accurate design temperature data it is easy to examine a load calculation and determine if the designer used an “extreme” temperature. To return to our example, a building official in Ft. Meyers should look for a summer design temperature of 93°F and a winter design temperature of 47°F (Figure 1), and his or her counterpart in Ames should look for a winter design temperature of 6°F and a summer design temperature of 90°F (Figure 2). Anything outside of these ranges does not comply with the recognized procedure of ACCA Manual J prescribed by the 2006 IRC.

Indoor heating and cooling design temperatures that will satisfy most occupants are also available from ACCA<sup>2</sup>: 70°F for winter heating and 75°F for summer cooling.<sup>3</sup> Of course, the subjective indoor conditions provided for one homeowner may be too high or too low for another, but HVAC designers should carefully document the justification for choosing anything but these common design temperatures.

Basically, ACCA Manual J considers four factors: the temperature difference (indoor and outdoor), the ability of heat to pass through the various building components (walls, windows, doors, etc.), the area of the space conditioned and moisture. The difference between the inside and outside temperatures is one of the basic

Worksheet A Location and Design Conditions Cobb Residence			
State: Florida	City: Ft. Myers	Elevation = 15 Ft	Latitude = 26°
Indoor Conditions, Heating: DB	70 °F	RH =	Indoor Conditions, Cooling: DB = 75 °F RH = 50%
Table 1 Conditions	99% DB = 47 °F	1% DB = 93 °F	Grains Difference = 53 Daily Range = Medium
Design Temperature Differences	HTD = 70 - 47 = 23 °F		CTD = 93 - 75 = 18 °F

Figure 1. Ft. Meyers, Florida, ACCA residential design worksheet.

Worksheet A Location and Design Conditions			
State: Iowa	City: Ames	Elevation = 955 Ft	Latitude = 42 Degrees North
Indoor Conditions, Heating: DB	70 °F	RH = 20%	Indoor Conditions, Cooling: DB = 75 °F RH = 50%
Table 1 Conditions	99% DB = -6 °F	1% DB = 90 °F	Grains Difference = 38 Daily Range = Medium
Design Temperature Differences	HTD = 70 - (-6) = 76 °F		CTD = 90 - 75 = 15 °F

Figure 2. Ames, Iowa, ACCA residential design worksheet.



# GSSN

# MECHANICAL CONSULTING SERVICES

— RESIDENTIAL — COMMERCIAL — NEW CONSTRUCTION — BUILD-OUTS —

- ***Providing Heat Loss/Gain Calculations and System Design***
- ***Processing of County Permit Applications***
- ***Accurate Project Details, Installation & Inspection Checklists***
- ***On Site Walk Throughs***
- ***Complete Duct Design & Materials List Available***

***For Fast, Reliable Service, Call***

***Office: 540-868-1146***  
***Mobile: 540-664-2788***

*Serving All Northern Virginia — All Major Credit Cards Accepted*



## Reviewing HVAC Designs (continued)

considerations for proper load calculation. If the HVAC system designer began the process with the wrong design conditions, the resulting load calculation can be completely inaccurate. Other factors include design humidity, altitude and latitude.

### Equipment Selection

The next step in HVAC design review is to look at equipment selection. Load calculations produce the values, in British thermal units per hour (Btu/h), for selecting the equipment. The best place to find these values is in the original equipment manufacturer (OEM) performance data. Most OEMs provide performance data that rate their equipment at different operating conditions. For example, a 2.5-ton air conditioner may be rated at a slightly higher capacity in Seattle, Washington, because of the mild climate but at a lower capacity in Phoenix, Arizona, because the unit cannot produce as much cool air when it is 108°F outside (the ACCA 1-percent design temperature). Figure 3 uses a fictitious air conditioner model to illustrate a performance swing of 15 percent or more based on the operating conditions.

### Duct Design

The evaluation of duct design is very subjective because of the wide varieties of layouts, fittings, etc. However, one aspect is very easy to evaluate: return air duct paths. ACCA Manual D, Section 1-4, provides that “there must be a low-resistance return air path between every room and the air handler (or furnace).” IRC Section M1403.1 refers to the “minimum unobstructed total area of the outside and return air ducts” for heat pumps. In other words, larger rooms that usually have their doors closed, such as bedrooms and home offices, pose a need for air to get back to the air handler or furnace.

If a low-resistance return air path is not present, the air handler or furnace creates negative pressure inside the home. This negative pressure draws air from fireplaces, the vent pipes for some furnaces and gas clothes dryers, and other fuel-burning appliances that use natural draft venting to carry away carbon monoxide (CO). As a result, the CO is not properly exhausted—posing a potentially serious health and safety risk. Reviewing the duct layout for large return grills in common areas and small return grills in rooms with normally closed doors

XYZ Air Conditioners – Detailed Cooling Capacities Model AC-30 with Coil AC-030							
Evaporator Air		Condenser Entering Air Temp – DB (F)					
CFM	EWB (F)	85		95		105	
		Capacity		Capacity		Capacity	
		Total	Sensible	Total	Sensible	Total	Sensible
875	72	34,610	18,190	33,100	17,620	31,520	17,020
	67	31,400	22,240	30,000	21,650	28,520	21,040
	63	28,620	26,290	27,350	25,680	26,020	25,040
	57	27,840	27,840	26,800	25,740	25,740	25,740
1000	72	35,250	19,090	33,680	18,500	32,030	17,890
	67	31,990	23,660	30,530	23,060	29,000	22,440
	63	29,020	29,020	28,020	26,560	26,770	26,770
	57	29,020	29,020	27,930	27,930	27,930	27,930
1125	72	35,720	19,920	34,110	19,920	32,500	19,920
	67	32,430	25,010	30,930	25,010	29,320	25,010
	63	29,970	29,970	28,850	28,850	27,640	27,640
	57	30,000	30,000	28,850	28,850	27,640	27,640

This A/C unit's capacities vary (from the nominal 30,530 Btu/h) based on the operating conditions inside and outside of the home.

Figure 3. Example air conditioner performance data.

## Reviewing HVAC Designs (continued)

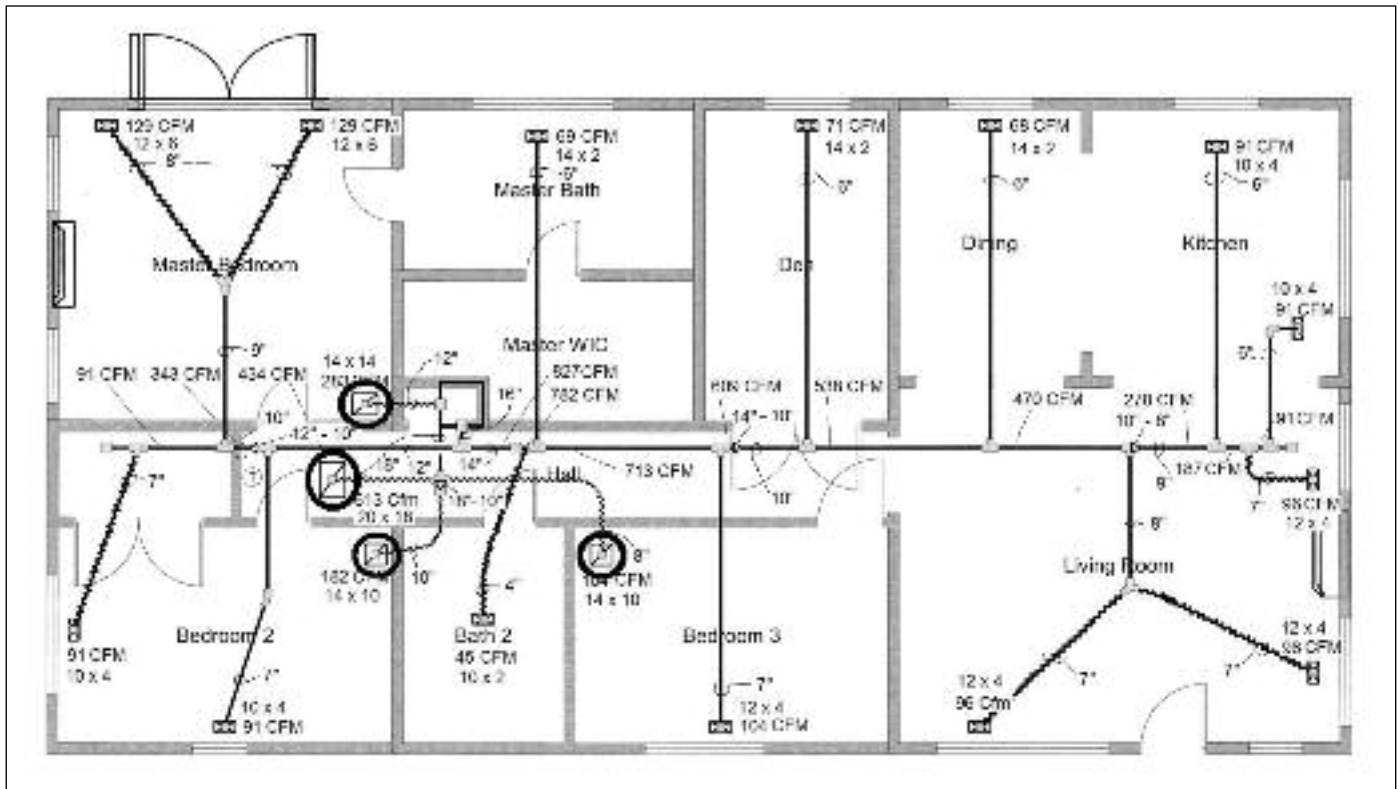

Figure 4. Example duct system layout.

can protect occupants from a backdrafting appliance and CO pollution.

A ducted return is one solution; another is crossover ducts or transfer grills. Undercuts on doors are also acceptable but could require the removal of one or more inches, which may be aesthetically undesirable. The duct system layout illustrated in Figure 4 shows one large return for the open common living areas and a ducted return for each bedroom.

Reviewing a residential HVAC system takes some time, but asking for the load calculation and duct design—and learning how to evaluate them—is relatively easy and contributes to protecting the health and safety of occupants. ♦

### Notes

1. As illustrated in Figures 1 and 2, the winter design temperature is expressed as 99 percent and the summer design temperature is expressed as 1 percent.
2. These temperatures are the “sweet spots” identified by the American Society of Heating, Refrigerating and Air-Conditioning Engineers based on extensive research.

3. The designer has the option of selecting dry 45-percent relative humidity (Rh), normal 50-percent Rh or damp 55-percent Rh.

**WES DAVIS** is Manager of Technical Services for the Air Conditioning Contractors of America (ACCA). In this capacity, one of his principle responsibilities is to assist the contracting community in developing tools and capabilities for energy-efficient, high-quality indoor environments. He also represents ACCA in interactions with other organizations.

To learn more about ACCA's activities, products and services visit its website at [www.acca.org](http://www.acca.org).

# — VPMIA Officers —

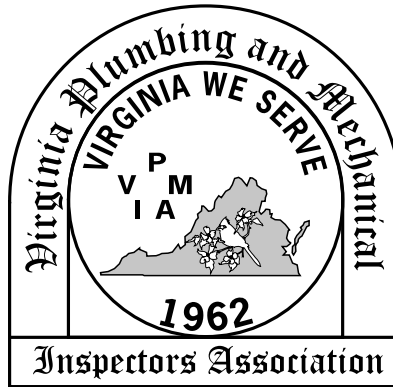

## 2007 VPMIA Board of Directors

<i>President</i>	<b>Dennis Martinelli</b>
<i>Vice President</i>	<b>John W. Mills</b>
<i>Secretary</i>	<b>John Michael Clift</b>
<i>Treasurer</i>	<b>Wayne Kushner</b>
<i>Executive Secretary</i>	<b>Geary Showman</b>

## 2007 Directors

Director at Large	John Seay
District 1	Ron Bladen
District 2	Gregory Stbanus
District 3	Bane F. Compton
District 4	John W. Mills
District 5	Louis Beck
District 6	Stanley J. Gregory, Jr.
District 7	John Micheal Cliff
District 8	David Harris

## 2007 Committee Chairmanships

Advertising/Yearbook	Ron Bladen
Audit	Geary Showman
Awards	John Seay
By-Laws / Parliamentarian	Charlie Gerber
Cert / Education / Training	Wayne Kushner
Finance	Geary Showman
Fuel Gas/Mechanical Code	Richard Grace
Legislative	Rick Witt
Mechanical Code	Richard Grace
Membership / Website	James Anjam
Nominating	John Seay
Plumbing Code	James Anjam
Residential Code	James Anjam
Resolutions	Paul Hostetler
School of Instruction	Wayne Kushner
Time and Place	Kathy Dye



At the 2007 Banquet, Dave Shapiro administered the oaths of office for incoming VPMIA President, Vice President, Treasurer and Secretary.

A

**Adams, Paul M.** (8)  
Life Member  
Post Office Box 1134  
Grandy, NC 27939  
252-453-6164  
Netmit@aol.com

Addie, Sonia (1)  
Plumbing Code Inspector  
Arlington County  
2100 Clarendon Blvd, Suite 800  
Arlington, VA 22201  
703-228-3866  
703-228-7406 FAX  
saddie@arlingtonva.us

Aldridge, William "Bill" (3)  
Building Inspector  
Town of Christiansburg  
100 East Main Street  
Christiansburg, VA 24073-3029  
540-382-6120 Ext 186  
540-381-7238 FAX  
baldridge@christiansburg.org

Allen, Michael L. (6)  
Code Enforcement Office  
City of Emporia  
P.O. Box 511  
Emporia, VA 23847  
434-634-6315  
434-634-0003 FAX  
mike.allen@ci.emporia.va.us

Altizer, Charles (6)  
Virginia State Fire Marshall, DHCD  
501 N. Second Street  
Richmond, VA 23219  
804-371-7154  
804-371-7092 FAX  
charles.altizer@dhcd.virginia.gov

Alves, Kenneth (8)  
Building Codes Inspector  
City of Newport News  
2400 Washington Avenue  
Newport News, VA 23607  
757-926-8865  
757-926-8311 FAX  
kalves@nngov.com

Amiri, Shahriar (1)  
Chief Building Official  
Arlington County  
2100 Clarendon Blvd, Suite 804  
Arlington, VA 22201  
703-228-3848  
703-228-7046 FAX  
samiri@arlingtonva.us

Anderson, Jeffrey H. (6)  
Residential Combination Inspector  
Chesterfield County  
PO Box 40  
Chesterfield, VA 23832  
804-814-7005  
804-778-7512 FAX  
andersonj@chesterfield.gov

Anjam, James (1)  
Manager, Inspection Section  
Arlington County  
2100 Clarendon Blvd, Suite 800  
Arlington, VA 22201  
703-228-3875  
703-228-7048 FAX  
janjam@arlingtonva.us

Antonowics, Ricky (1)  
Master Combination Inspector  
Fairfax County  
12055 Government Center Pkwy  
Fairfax, VA 22035  
703-324-1711  
703-324-3901 FAX  
rantonowics@fairfaxcounty.gov

B

Baker, Johnnie (1)  
Plumbing Plans Reviewer  
Loudoun County  
PO Box 7000 MSC 60B  
Leesburg, VA 20177-7000  
703-771-5756  
703-737-8546 FAX  
jbaker@loudoun.gov

**Baldwin, Jr., Edward J.** (2)  
Life Member  
City Of Harrisonburg  
409 S. Main Street  
Harrisonburg, VA 22801  
540-432-7700  
540-432-7777 FAX  
judb@ci.harrisonburg.va.us

Ballard, Jr., William H. (1)  
Cross Connection/Plumbing Inspector  
Arlington County  
2100 Clarendon Blvd, Suite 800  
Arlington, VA 22201  
703-228-3853  
703-228-7046 FAX  
W.Ballard@arlingtonva.us

Bartel, Tracy J. (6)  
Plumbing & Mechanical Inspector  
Henrico County  
PO Box 27032  
Richmond, VA 23273  
804-501-4231  
804-501-4984 FAX

Bartell, Richard (7)  
Chief Building Official  
Hanover County  
PO Box 470  
Hanover, VA 23069  
804-537-6039  
804-537-6247 FAX  
rabartell@co.hanover.va.us

Beahm, David (2)  
Building Official  
Warren County  
220 N. Commerce Avenue, #400  
Front Royal, VA 22630  
540-636-9973  
540-636-4698 FAX  
dbeahm@warrencountyva.net

Beavon, Jesse D. (5)  
Facilities Construction & Maintenance  
Manager  
Spotsylvania County  
PO Box 116  
Spotsylvania, VA 22553  
540-507-7702  
540-582-6304 FAX  
jbeavon@spotsylvania.va.us

Beck, JR., Louis, (5)  
Combination Inspector  
Goochland County  
PO Box 119  
Goochland, VA 23063  
804-556-5815 Ext 6209  
804-556-5651 FAX  
lbeck@co.goochland.va.us

Becker, David (1)  
Engineer  
Fairfax County  
12035 Government Ctr Pkwy, Suite 424  
Fairfax, VA 22035  
703-324-2849  
David.becker@fairfaxcounty.gov

Berkley, Arthur E. (8)  
Director of Inspections  
Isle Of Wight County  
PO Box 80  
Isle Of Wight, VA 23314  
757-365-6216  
757-357-0771 FAX  
aberkley@isleofwightus.net

Bladen, Ron (1)  
Code Specialist II  
Fairfax County  
12055 Gov Center Pkwy, Suite 324  
Fairfax, VA 22035  
703-324-1651  
703-324-1614 FAX  
ronald.bladen@fairfaxcounty.gov

Boomer, Jr., Bernard (2)  
Combination Inspector  
City of Newport News  
2400 Washington Avenue  
Newport News, VA 23607  
757-926-8773  
757-926-8311 FAX

# Active Membership Roster —

**Borders, Stephen P.** (5)  
Life Member  
Building Official  
Greene County  
PO Box 358  
Stanardsville, VA 22973  
434-985-5204  
434-985-1459 FAX  
sborder@gcva.us

**Boylan, Daniel** (1)  
Mechanical Inspector  
Loudoun County  
PO Box 7000 MSC 60B  
Leesburg, VA 20177-7000  
703-771-5031  
703-737-8546 FAX

**Branner, Tommy** (2)  
Building Codes Inspector  
City of Harrisonburg  
409 South Main Street  
Harrisonburg, VA 22802  
540-432-7700  
tommyb@ci.harrisonburg.va.us

**Brooking, Michael** (5)  
Building Inspector  
Goochland County  
PO Box 119  
Goochland, VA 23063  
804-556-5651  
mbrooking@co.goochland.va.us

**Brown, Mike** (1)  
Master Inspector  
Fairfax County  
12055 Government Center Pkwy  
Fairfax, VA 22035  
703-324-1679  
703-324-1846 FAX  
Michael.Brown2@fairfaxcounty.gov

**Brunkow, Paul** (7)  
Building Official  
Westmoreland County  
PO Box 100  
Montross, VA 22520  
804-493-0120  
804-496-0604 FAX  
buildings@westmoreland-county.org

**Bryan, Jerry** (6)  
Mechanical Inspector  
City of Richmond  
900 E. Broad Street, #110  
Richmond, VA 23219  
804-646-6983  
804-646-6948 FAX  
bryanjw@ci.richmond.va

**Bryant, Clyde** (8)  
Senior Code Specialist  
City of Norfolk  
400 Granby Street  
Norfolk, VA 23510-1914  
757-664-6536  
757-664-6841 FAX  
clyde.bryant@norfolk.gov

**Bryant, Sam** (8)  
Senior Code Specialist  
City of Norfolk  
400 Granby St.  
Norfolk, VA 23510-1914  
757-664-6551  
757-664-6841 FAX  
Sammy.bryant@norfolk.gov

## C

**Caleb, Sulzen** (5)  
Building Inspector  
Louisa County  
PO Box 160  
Louisa, VA 23093  
540-967-3430  
540-967-3486 FAX  
csulzen@louisa.org

**Campbell, Curtis W.** (6)  
Combination Building Inspector  
Chesterfield County  
PO Box 40  
Chesterfield, VA 23832  
804-814-7003  
804-778-7512 FAX  
campbellcw@chesterfield.gov

**Catan-Rose, Paula** (1)  
Mechanical/Elevator Inspector  
Loudoun County  
PO Box 7000 MSC 60B  
Leesburg, VA 20177-7000  
703-737-8744  
703-737-8546 FAX

**Christian, Carl** (8)  
Plumbing Inspector Supervisor  
City of Virginia Beach  
2405 Courthouse Drive  
Virginia Beach, VA 23456  
757-427-4211  
757-426-5777 FAX

**Clayborn, Steven** (1)  
Supervising Combination Inspector  
Fairfax County  
12055 Government Center Pkwy,  
Suite 634  
Fairfax, VA 22035  
703-324-1971  
703-324-1846 FAX  
sjc36chevy@aol.com

**Clements, Darin** (5)  
Plumbing/Mechanical Inspector  
City of Charlottesville  
PO Box 911  
Charlottesville, VA 22902  
434-970-3317  
434-970-3359 FAX  
clementd@charlottesville.org

**Clift, John Michael** (7)  
Building Official  
King George County  
10459 Courthouse Rd #104  
King George, VA 22485  
540-775-8557  
540-775-3139 FAX  
mclift@co.kinggeorge.state.va.us

**Cole, Frank R.** (1)  
Engineer III  
Fairfax County  
12055 Government Center Pkwy,  
Suite 316  
Fairfax, VA 22035  
703-324-1688  
703-324-1614 FAX  
frank.cole@fairfaxcounty.gov

**Compton, Bane F.** (3)  
Combination Inspector  
City of Roanoke  
215 Church Avenue, Room 170  
Roanoke, VA 24011  
540-853-1139  
540-853-1594 FAX  
bane.compton@roanokeva.gov

**Cooper, John G.** (6)  
Plumbing Plans Reviewer  
Henrico County  
PO Box 27032  
Richmond, VA 23273  
804-501-4371  
804-501-4984 FAX  
coo07@co.henrico.va.us

**Cooper, John L.** (1)  
Combination Inspector  
Fairfax County  
211. West Main St  
Purcellville, VA 20133  
703-989-3173  
540-338-2442 FAX

**Cooper, Kevin** (5)  
Government Inspector  
Alutiiq International, LLC.  
2055 Boulders Road  
Charlottesville, VA 22911  
434-951-4737

**Cousins, Paul** (8)  
Mechanical Plan Examiner  
City of Hampton  
22 Lincoln Street  
Hampton, VA 23669  
757-727-6676  
757-727-6557 FAX  
pcousins@hampton.gov

**Craddock, Ron** (5)  
Government Inspector  
Alutiiq International, LLC.  
2055 Boulders Road  
Charlottesville, VA 22911  
434-951-4737  
ron.craddock@us.army.mil

**Cubbage, Gary Lee** (1)  
Mechanical Inspector  
Loudoun County  
PO Box 7000  
1 Harrison Street, S.E.  
Leesburg, VA 20177-7000  
703-771-5684  
703-737-8546 FAX  
Gary.Cubbage@loudoun.gov

— Active Roster Continued —

D

Davis, Stephen (2)  
Deputy Building Official  
Rockingham County  
PO Box 1252  
Harrisonburg, VA 22803  
540-564-3057  
540-564-2922 FAX

Decatur, Thomas (1)  
Plumbing Plans Reviewer  
Arlington County  
2100 Clarendon Blvd, Suite 804  
Arlington, VA 22201  
703-228-3856  
703-228-7046 FAX

Deel, Gary (4)  
Building Official  
Dickerson County  
PO Box 773  
Clintwood, VA 24228  
276-926-1673  
276-926-6227 FAX  
gary.deel@bid.dcin.org

**DeHaven, Larry H.** (2)  
Life Member  
107 North Kent Street  
Winchester, VA 22601  
540-665-5656  
540-678-0682 FAX

Dellenger, Michael (2)  
Plan Review/Building Codes  
City Of Harrisonburg  
409 S. Main Street  
Harrisonburg, VA 22801  
540-432-7700  
540-432-7777 FAX  
miked@ci.harrisonburg.va.us

DeMaury, Andrew (3)  
Building Official  
Montgomery County  
PO Box 2506  
Christiansburg, VA 24068  
540-382-5750  
540-381-6880 FAX

Derrer, Terry (2)  
Combination Inspector  
Rockingham County  
PO Box 1252  
Harrisonburg, VA 22803  
540-564-3040  
540-564-2922 FAX

**DeShazo, Hassell** (3)  
Life Member  
6783 Mitchell Rd  
Ridgeway, VA 24148  
276-956-2499

Dolan, Michael (3)  
Building Official  
City of Covington  
333 W. Locust Street  
Covington, VA 24426  
540-965-6356  
540-965-6307 FAX  
mdolan@covington.va.us

Duckworth, William N. (8)  
Combination Inspector  
City of Portsmouth  
801 Crawford Street  
Portsmouth, VA 23704  
757-393-8531  
757-393-5108 FAX  
duckworthw@portsmouthva.us

Duffy, Dave (5)  
Building Official  
Goochland County  
PO Box 119  
Goochland, VA 23063  
804-556-5351  
804-556-5651 FAX  
dduffy@co.goochland.va.us

Dupler, William (6)  
Building Official  
Chesterfield County  
PO Box 40  
Chesterfield, VA 23832  
804-748-1611  
804-751-4713 FAX  
duplerd@co.chesterfield.va.us

Duvall, William J. (7)  
Plumbing/Mechanical Inspector  
Hanover County  
PO Box 470  
Hanover, VA 23069  
804-365-6138  
804-365-6465 FAX  
wjduvall@co.hanover.va.us

**Dye, Kathleen T.** (1)  
Life Member  
Retired  
8728 Sugarwood Lane  
Manassas, VA 20110-3847  
703-368-5714

Dyer, Lorenzo (6)  
State Building Code  
Senior Engineer, DHCD  
501 N. Second Street  
Richmond, VA 23219  
804-371-7160  
804-371-7092 FAX  
lorenzo.dyer@dhcd.virginia.gov

E

Elder, Gregory (7)  
Building Inspector  
King George County  
10459 Courthouse Road, #104  
King George, VA 22485  
540-775-3061  
540-775-3139 FAX  
gelder@co.kinggeorge.state.va.us

Ely II, George (6)  
Mechanical Inspector  
City of Richmond  
900 East Broad Street, #110  
Richmond, VA 23219  
804-646-6984  
804-646-6948 FAX

English, Jimmy (3)  
Building & Code Official  
City Of Bedford  
PO Box Drawer 807  
Bedford, VA 24523  
540-587-6021  
540-875-7533 FAX  
jenglish@ci.bedford.va.us

Eppard, Bonne L. (5)  
Building Inspector  
Greene County  
PO Box 358  
Stanardsville, VA 22973  
434-985-5204  
434-985-1459 FAX  
beppard@gcva.gov

Estep, Brian  
Building Inspector  
Prince George County  
PO Box 68  
Prince George, VA 23875  
804-722-8643  
804-722-0702 FAX  
bestep@princegeorgeva.org

F

Farrow, Ray (8)  
Mechanical Inspector  
City of Norfolk  
400 Granby St.  
Norfolk, VA 23510-1914  
757-664-6559  
757-664-6897 FAX  
raymond.farrow@norfolk.gov

Fauber, David (8)  
Building Inspector  
Town of Cape Charles  
2 Plum Street  
Cape Charles, VA 23310  
757-331-2176  
757-331-4820 FAX

Fields, Thomas (1)  
Plumbing Inspector  
Loudoun County  
PO Box 7000 MSC 60B  
Leesburg, VA 20177-7000  
703-771-5759  
703-737-8546 FAX  
trfjr2@shentel.net

Fix, Fred (3)  
Building Official  
City of Buena Vista  
2039 Sycamore Ave  
Buena Vista, VA 24416  
540-261-8635  
540-261-2142 FAX  
inspector@buenavistava.com

Fletcher, Walter (2)  
Plumbing/Mechanical/Gas Inspector  
City of Winchester  
15 N. Cameron Street, #410  
Winchester, VA 22601  
540-667-1815  
540-722-3618 FAX  
fletcherwr@ci.winchester.va.us

Forrest, David (8)  
Combination Inspector  
City of Newport  
2400 Washington Avenue  
Newport News, VA 23607  
757-926-8864  
757-926-8311 FAX  
dforrest@nngov.com

Fortner, Richard S. (8)  
Senior Codes Specialist/Mechanical  
City of Norfolk  
400 Granby Street  
Norfolk, VA 23510-1914  
757-664-6547  
757-664-6897 FAX  
richard.fortner@norfolk.gov

Foster, Rodney  
Building Official  
Town of Colonial Beach  
18 N. Irving Avenue  
Colonial Beach, VA 22443  
804-224-7214  
804-224-7185 FAX  
cbbuild@3n.net

Frazier, Edwarren (5)  
Building Inspector  
Madison County  
PO Box 1206  
Madison, VA 22727  
540-948-6102  
540-948-3843 FAX  
cmycuts1@yahoo.com

Frivetti, Don (6)  
Inspector  
City of Richmond  
900 East Broad Street, #110  
Richmond, VA 23219  
804-646-6981  
804-646-6948 FAX

Fulcher, Jr., Chas.W. (3)  
Inspections Division Supervisor  
City of Danville  
PO Box 3300  
Danville, VA 24541  
434-799-5263 Ext 232  
434-797-8919 FAX  
fulchew@ci.danville.va.us

G

Gerber, Charles E. (6)  
Plumbing/Mechanical Supervisor  
County of Henrico  
PO Box 27032  
Bldg. Insp. Department  
Richmond, VA 23273  
804-501-4369  
804-501-4984 FAX  
ger02@co.henrico.va.us

Gilbert, William (5)  
Commercial Inspections Chief  
Albemarle County  
401 McIntire Rd, #211  
Charlottesville, VA 22902  
434-296-5831  
434-972-4126 FAX  
w.gilbert@albemarlecounty.org



**Laurie/Daniel Crigler**  
**(540) 948-6230 Fax (540) 948-5617**

**Plumbing • Hydronic Heating  
Consulting • Project Management  
Class "A" License #069344**

**P.O. Box 418  
Aroda, Virginia 22709**

Gill, Bernie (1)  
Construction Codes IV  
Arlington County  
2100 Clarendon Blvd, Suite 804  
Arlington, VA 22201  
703-228-3873  
703-228-7046 FAX  
bgill@arlingtonva.us

Gillispie, Gary L. (1)  
Plumbing Inspector  
Loudoun County  
PO Box 7000 MSC 60B  
Leesburg, VA 20177-7000  
703-737-8298

Glascocock, Earnest (1)  
Combination Inspector  
Prince William County  
5 County Complex Court  
Prince William, VA 22192  
703-792-7102  
703-580-1578 FAX  
eglascock@pwcgov.org

Grabowski, Francis A. (8)  
Code Inspector  
City of Virginia Beach  
2505 Courthouse Drive  
Virginia Beach, VA 23456  
757-385-8066  
757-385-5777 FAX

Grace, Richard E. (1)  
Engineer III, Plan Review Division  
Fairfax County  
12055 Government Center Pkwy,  
Suite 316  
Fairfax, VA 22035  
703-324-1687  
703-314-1614 FAX  
richard.grace@fairfaxcounty.gov

Gray, Dale (1)  
Inspections  
Loudoun County  
PO Box 7000 MSC 60B  
Leesburg, VA 20177-7000  
703-777-0555  
703-737-8546 FAX

Gray, Daniel (8)  
Combination Inspector  
City of Portsmouth  
801 Crawford Street  
Portsmouth, VA 23704  
757-393-8531  
757-393-5108 FAX  
grayd@portsmouth.gov

Gregory, Jr., Stanley "Joe" (6)  
Building Inspector III  
Chesterfield County  
P.O. Box 40  
Chesterfield, VA 23832  
804-814-6979  
804-778-7512 FAX  
gregorys@chesterfield.gov

Grimmell, Mark (1)  
Plumbing & Gas Field Supervisor  
Loudoun County  
PO Box 7000  
1 Harrison Street, S.E.  
Leesburg, VA 20177-7000  
703-771-5765  
703-737-8546 FAX  
Mark.Grimmell@loudoun.gov

Grivetti, Don (1)  
Plumbing Inspector  
City of Richmond  
900 East Broad Street, #110  
Richmond, VA 23219  
804-646-6636  
grivettidc@ci.richmond.va.us

H

Haga, Jamie (4)  
Building Inspector  
Grayson County  
PO Box 217  
Independence, VA 24348  
276-773-2322  
276-773-3673 FAX  
gobi2@adelphia.net

Haines, Cheri (8)  
Building Code Administrator  
City of Virginia Beach  
2405 Courthouse Drive  
Virginia Beach, VA 23456  
757-385-4211  
757-385-5777 FAX

Hale, Jr., Robert (1)  
Building Official  
Town of Warrenton  
18 Court Street  
Warrenton, VA 20188  
540-347-2405  
540-347-2414 FAX  
rhale@warrentonva.gov



## PLUMBING *and* HEATING

*Service • Remodeling • New Construction • Septic Systems  
Excavating • Electrical Repairs & Service Upgrades  
Well Pump Repair, Replacement & New Installation*

**“OUR SERVICE IS OUR SALE”**

www.eandemplumbing.com

**(540) 337-1856 • (540) 943-7727 • (540) 337-9453**

296 Draft Avenue Stuarts Draft, VA 24477

VA Contractors Lic. #2705 040015A

Hardee, Cecil F. Jr. (1)  
Section Supervisor  
Fairfax County Park Authority  
12055 Government Center Pkwy  
Fairfax, VA 22035  
703-324-8434  
703-324-3987 FAX  
cecil.hardee@fairfaxcounty.gov

Harper, Skip (5)  
Building Inspector  
Louisa County  
PO Box 160  
Louisa, VA 23093  
540-967-3430  
540-967-3486 FAX  
sharper@louisa.org

Harris, David R. (8)  
Senior Building Codes Inspector  
City of Newport News  
2400 Washington Avenue  
Newport News, VA 23607  
757-926-8866  
757-926-8311 FAX  
dharris@nngov.com

Harsh, Anthony (1)  
Plumbing & Gas Inspector  
Loudoun County  
1 Harrison Street, S.E.  
Leesburg, VA 20177-7000  
703-777-0575  
703-737-8546 FAX  
Andy.Harsh@loudoun.gov

Haskett, James (8)  
Senior Code Specialist  
City of Norfolk  
400 Granby St.  
Norfolk, VA 23510-1914  
757-664-6553  
757-664-6897 FAX  
jim.hasket@norfolk.gov

Hatcher, Sr., Ricky Lee (8)  
Plumbing/Mechanical Inspector  
City of Hampton  
22 Lincoln Street  
Hampton, VA 23669  
757-727-6287  
757-727-6557 FAX  
rhatcher@hampton.gov

Heddings, Joseph (3)  
Building Official  
Campbell County  
PO Box 100  
Rustburg, VA 24588  
434-332-9608  
434-332-9693 FAX  
jlheddings@co.campbell.va.us

Herron, Rick (7)  
Building Inspector  
King George County  
10459 Courthouse Road, #104  
King George, VA 22485  
540-775-7111  
540-775-3139 FAX  
rherron@co.kinggeorge.state.va.us

Hewitt, William (8)  
Combination Inspector  
City of Portsmouth  
801 Crawford Street  
Portsmouth, VA 23704  
757-393-8531  
757-393-5108 FAX  
hewitt@portsmouthva.gov

Hines, William F. (1)  
Life Member  
4086 Stanberry Avenue  
Marshall, VA 20115  
540-364-2934  
william.hines@fauquier.county.gov

Hodges, Jeffrey (7)  
Building & Zoning Official  
Essex County Tappahannock  
PO Box 549  
Tappahannock, VA 22450  
804-443-4951  
804-443-4157 FAX  
jeffhodges@hotmail.com

Hostetler, Paul D. (5)  
Life Member  
Retired  
518 Pebble Hill Court  
Charlottesville, VA 22901  
434-964-1183  
paulhostetler@peoplepc.com

Hudson, Brad (7)  
Building Technical Assistant  
King George County  
10459 Courthouse Road, #104  
King George, VA 22485  
540-775-8554  
540-775-3139 FAX  
bhudson@co.kinggeorge.state.va.us

Hudson, Charles (6)  
Building/Code Official  
Town of South Hill  
211 South Mecklenburg Avenue  
South Hill, VA 23970  
434-447-5041  
434-447-5064 FAX  
chudson@southhillva.org

Humrich, Rex R. (8)  
Plumbing Inspector  
City of Virginia Beach  
2405 Courthouse Drive  
Virginia Beach, VA 23456  
757-385-8066

Hunter, Robert Joseph (8)  
Cross Connection Specialist  
City of Norfolk  
400 Granby Street  
City of Norfolk, VA 23510  
757-664-6832  
757-664-6841 FAX  
robert.hunter@norfolk.gov

Hurt, Jesse R. (5)  
Life Member  
18060 James Madison Highway  
Gordonsville, VA 22942  
540-832-3767

Hutto, J. Ralph (6)  
Plumbing Inspector  
City of Richmond  
900 East Broad Street, #110  
Richmond, VA 23224  
804-737-3907  
804-646-6948 FAX



— Active Roster Continued —

J

Johnson, Michael (8)  
Mechanical Inspector  
City of Newport News  
2400 Washington Avenue  
Newport News, VA 23607  
757-926-8860  
757-926-8311 FAX  
mrjohnson@nngov.com

Jones, Frank D. (8)  
Mechanical Inspector  
City of Virginia Beach  
2405 Courthouse Drive  
Virginia Beach, VA 23456  
757-427-8065  
757-426-5777 FAX

K

Kesner, Marty (1)  
Plumbing Inspector  
Loudoun County  
PO Box 7000 MSC 60B  
Leesburg, VA 20177-7000  
703-737-8297

Kidd, David (3)  
Building Code Engineer  
Virginia Tech  
1240 Smith Creek Road  
Christiansburg, VA 24073  
540-231-9578  
540-231-5590 FAX  
dmkidd@vt.edu

Kipps, Kenneth (1)  
Plumbing Inspector  
Loudoun County  
PO Box 7000 MSC 60B  
Leesburg, VA 20177-7000  
703-737-8019  
703-737-8546 FAX

Koll, Paul (7)  
Building Official  
Gloucester County  
PO Box 604  
Gloucester, VA 23061  
804-693-2744  
804-693-4664 FAX  
pkoll@gloucesterva.info

Kurtz, Dennis (5)  
Plan Review  
Culpeper County  
302 N. Main Street  
Culpeper, VA 22701  
540-727-3405  
540-727-3461 FAX  
dkurtz@culpepercounty.gov

Kushner, Wayne (1)  
Commercial Combination Inspector  
Fairfax County  
12055 Government Center Pkwy  
Fairfax, VA 22035  
703-324-1755  
703-324-1846 FAX  
wayne.kushner@fairfaxcounty.gov

L

Lam, Boyd W. (2)  
Building Official  
Rockingham County  
20 E. Gay Street  
Harrisonburg, VA 22802  
540-564-3030  
540-564-2922 FAX

Laney, Ricky F. (5)  
Residential Inspector  
Spotsylvania County  
PO Box 220  
Spotsylvania, VA 22553  
540-507-7242  
540-507-7281 FAX  
rlaney@spotsylvania.va.us

Laprade, Mike (3)  
Plumbing/Cross Connection  
Danville  
PO Box 330  
Danville, VA 24540  
434-799-5263  
434-797-8919 FAX  
laprajm@ci.danville.va.us

Latuche, Sr., Randall (7)  
Plumbing Inspections  
City of Richmond  
900 East Broad Street, #110  
Richmond, VA 23219  
804-646-3988  
804-646-6948 FAX  
latuchera@ci.richmond.va.us

Lawrence, Jr., Billy J. (8)  
Mechanical Inspector  
City of Newport News  
2400 Washington Avenue  
Newport News, VA 23607  
757-926-8106  
757-926-8311 FAX  
blawrence@nngov.com

Leatherby, Eric (6)  
Safety Engineer, DHCD  
501 N. Second Street  
Richmond, VA 23219  
804-371-7165  
804-371-7092 FAX  
eric.leatherby@dhcd.virginia.gov

Lee, Jason (1)  
Construction Code Inspector  
Arlington County  
2100 Clarendon Blvd, Suite 804  
Arlington, VA 22201  
703-228-3850  
703-228-7046 FAX  
jlee3@arlingtonva.us

Lester, Darius (5)  
Building Official  
Fluvanna County  
PO Box 540  
Palmyra, VA 22963  
434-591-1935  
434-591-1911 FAX  
dlester@co.fluvanna.va.us

**Lester, Ernest L. "Bud"** (1)  
Life Member  
Retired  
612 West Holly Avenue  
Sterling, VA 20164  
703-430-7898

Lewis, Michael G. (1)  
Construction Code Supervisor  
Arlington County  
2100 Clarendon Blvd, Suite 804  
Arlington, VA 22201  
703-228-3868  
703-228-7046 FAX

**Liggan, Joseph R.**  
Life Member (Retired)  
PO Box 652  
Mechanicsville, VA 23111  
804-769-2755

Lilly, Wayne (6)  
Senior Building Code Inspector  
City of Harrisonburg  
PO Box 20031  
Harrisonburg, VA 22801  
540-432-7700  
540-432-7777 FAX  
wayne@ci.harrisonburg.va.us

Lindstrom, Paul (8)  
Mechanical Inspector  
City of Newport News  
2400 Washington Avenue  
Newport News, VA 23607  
757-926-6925  
757-926-8311 FAX  
plindstrom@nngov.com

Lipscomb, J. Lee (6)  
Plumbing/HVAC Inspect. Supervisor  
Chesterfield County  
PO Box 40  
Chesterfield, VA 23832  
804-748-1309  
804-778-7512 FAX  
LipscombL@chesterfield.gov

Littlefield, Casey (5)  
Building Inspector  
Louisa County  
1 Woolfolk Avenue  
Louisa, VA 23093  
540-967-3430  
540-967-3486 FAX  
clittlefield@louisa.org

Lockhart, Bobby (1)  
Plumbing Inspector/Plan Review  
Loudoun County  
PO Box 7000 MSC 60B  
Leesburg, VA 20177-7000  
703-771-5065  
703-737-8546 FAX

— Active Roster Continued —

Lockhart, Scott (1)  
Plumbing Inspector  
Loudoun County  
PO Box 7000 MSC 60B  
Leesburg, VA 20177-7000  
703-771-5768  
703-737-8546 FAX

Lockhart, William (1)  
Plumbing Inspector  
Loudoun County  
PO Box 7000 MSC 60B  
Leesburg, VA 20177-7000  
703-771-5768  
703-737-8546 FAX

Lucas, James (7)  
Plumbing Inspector  
City of Richmond  
900 East Broad Street, #110  
Richmond, VA 23219  
804-646-680  
804-646-6948 FAX  
lucasjn@ci.richmond.va.us

Lucy, Herb (7)  
Plumbing/Mechanical Inspector  
Hanover County  
PO Box 470  
Hanover, VA 23069  
804-730-6062

Lynch, Paul (1)  
Director, Residential Inspections  
Division  
Fairfax County  
12055 Government Center Pkwy  
Fairfax, VA 22035  
703-324-1972  
703-324-3901 FAX  
plynch@fairfaxcounty.gov

---

M

Makely, James A. (1)  
Combination Inspector  
Fairfax County  
12055 Government Center Pkwy,  
Suite 634  
Fairfax, VA 22035  
703-324-1707  
703-324-3901 FAX  
james.makeley@fairfaxcounty.gov

Marcum, George (1)  
Combination Inspector  
Prince William County  
5 County Complex Court  
Prince William, VA 22192  
703-792-4608  
703-580-1578 FAX  
gmarcum@pwcgov.org

Marsh, JR., Robert E. (1)  
Plumbing Inspector  
Loudoun County  
PO Box 7000 MSC 60B  
Leesburg, VA 20177-7000  
703-771-5956  
703-771-8546 FAX

Martin, Christopher (1)  
Plumbing Inspector  
Arlington County  
2100 Clarendon Boulevard  
Arlington, VA 22201  
703-228-3854  
703-228-7046 FAX  
cmmartin@arlingtonva.us

Martinelli, Dennis (1)  
Supervising Combination Inspector  
Fairfax County  
12055 Government Center Pkwy  
Fairfax, VA 22035  
703-324-1637  
703-324-1846 FAX  
dennis.martinelli@fairfaxcounty.gov

Massie, Stan (4)  
Building Official  
Town of Wytheville  
P.O. Box 533  
Wytheville, VA 24382  
276-223-3339  
276-223-3315 FAX  
stanm@wytheville.org

Matkins, Janet (5)  
Building Inspector  
Louisa County  
PO Box 160  
Louisa, VA 23093  
540-967-3430  
540-967-3486 FAX  
jmatkins@louisa.org

Mayhew, Darrell (7)  
Plumbing-Mechanical Inspector  
Hanover County  
PO Box 470  
Hanover, VA 23069  
804-798-5842

McErlean, Edwin "Chip" A. (8)  
Chief Inspector  
City of Hampton  
Codes Compliance Office  
22 Lincoln Street  
Hampton, VA 23669  
757-727-6268  
757-727-6557 FAX  
cmcerlean@hampton.gov

**McFarland, Jr., Roy N.** (3)  
Life Member  
Cross Connection/Program Coordinator  
Roanoke County  
215 Church Avenue, Room 170  
Roanoke, VA 24011-1592  
540-853-1132  
540-853-1594 FAX  
roy.mcfarland@co.roanokeva.us

McIver, Curtis (6)  
Associate Director, DHCD  
501 N. Second Street  
Richmond, VA 23219  
804-371-7161  
804-371-7092 FAX  
curtis.mciver@dhcd.virginia.gov

McLehaney, Dustin (6)  
Inspector  
Chesterfield County  
PO Box 40  
Chesterfield, VA 23832  
804-317-6420  
804-778-7512 FAX  
mclehaneyd@chesterfield.gov

McMahan, Alan (6)  
Building Code Supervisor, DHCD  
501 N. Second Street  
Richmond, VA 23219  
804-371-1157  
804-371-7092 FAX  
alan.mcmahan@dhcd.virginia.gov

McMahan, Anthony (8)  
Plumbing/Mechanical Inspector  
Gloucester County  
PO Box 604  
Gloucester, VA 23061  
804-693-2744  
804-693-7037 FAX  
amcmahan@gloucestervera.info

McNaughton, Dennis (1)  
Engineer III  
Fairfax County  
12055 Government Center Pkwy,  
Suite 316  
Fairfax, VA 22035  
703-324-1643  
703-324-1614 FAX  
dennis.mcnaughton@fairfaxcounty.gov

McWhirt, Scott (5)  
Combination Residential Inspector  
Spotsylvania County  
PO Box 220  
Spotsylvania, VA 22553  
540-507-7245  
540-507-7281 FAX  
smcwhirt@spotsylvania.va.us

Meadows, Chris (1)  
Plumbing Inspector  
Loudoun County  
PO Box 7000 MSC 60B  
Leesburg, VA 20177-7000  
703-737-8547  
703-737-8546 FAX

Mentzer, Delbert (1)  
Mechanical Inspector  
Loudoun County  
PO Box 7000 MSC 60B  
Leesburg, VA 20177-7000  
703-737-8736  
703-737-8546 FAX

Milbourne, Jerry (1)  
Mechanical Inspector  
Loudoun County  
PO Box 7000 MSC 60B  
Leesburg, VA 20177-7000  
703-737-8718  
703-771-8546 FAX

Milbourne, Michael (1)  
Mechanical Inspector  
Loudoun County  
PO Box 7000 MSC 60B  
Leesburg, VA 20177-7000  
703-737-8742  
703-737-8546 FAX

— Active Roster Continued —

Mills, John W. (3)  
Building Official  
Giles County  
315 North Main Street  
Pearisburg, VA 24134  
540-921-2527  
540-921-1846 FAX  
hsnidow@gilescounty.org

Mimms, Donald (6)  
Plumbing/Mechanical Inspector  
Chesterfield County  
PO Box 40  
Chesterfield, VA 23832  
804-814-6999  
804-778-7512 FAX  
mimmsd@co.chesterfield.va.us

Moore, James (1)  
Supervising Combination Inspector  
Fairfax County  
12055 Government Center Pkwy  
Fairfax, VA 22035  
703-324-1704  
703-324-1846 FAX  
james.moore@fairfaxcounty.gov

More, Allen (8)  
Mechanical Inspector  
City of Virginia Beach  
2405 Courthouse Drive  
Virginia Beach, VA 23456  
757-427-8065  
757-426-5777 FAX

Morgan, Michael (8)  
Senior Code Specialist  
City of Norfolk  
400 Granby Street  
Norfolk, VA 23510-1914  
757-664-6733  
757-664-6841 FAX  
michael.morgan@norfolk.gov

Moss, James (5)  
Building Official  
Grayson County  
PO Box 217  
Independence, VA 24348  
276-773-2322  
276-773-3673 FAX  
bring@valink.com

Motely, Ralph (8)  
Plumbing/Mechanical Inspector  
York County  
103 Service Drive  
Yorktown, VA 23692  
757-890-3522  
757-890-3549 FAX  
ralph.motley@yorkcounty.gov

Murphy, Patrick (6)  
Chief Electrical/Plumbing Inspector  
Code Administrator  
City of Richmond  
900 East Broad Street, #110  
Richmond, VA 23219-6505  
804-646-6962  
804-646-6948 FAX  
murphypj@ci.richmond.va.us

Murrell, Bernie (6)  
Building Official  
City of Colonial Heights  
201 James Avenue  
Colonial Heights, VA 23832  
804-520-9298  
804-524-8755 FAX  
murellb@colonial-heights.com

Myers, Kenneth D. (1)  
Senior Building Inspector  
Stafford County  
1300 Court House Rd.  
Stafford, VA 22555  
540-658-4661  
540-727-3461 FAX  
KMyers@co.stafford.va.us

N

Negley, Valrae (5)  
Building/Fire Official  
Spotsylvania County  
PO Box 220  
Spotsylvania, VA 22553  
540-507-7232

Nelson, Richard (2)  
Building Official  
City of Winchester  
15 N. Cameron Street, #410  
Winchester, VA 22601  
540-667-1815  
540-722-3618 FAX  
nelson@ci.winchester.va.us

**Over 50 Years of Trusted Service**

 **LEONARD-SPLAINE** Heating & Cooling

**Quality Equipment ~ Expert Installation ~ Prompt Service**

**FEATURING**

-  **TRANE**
-  **HEP**

Quiet, Durable and Energy Efficient with Aerodynamic Air Flow

- Residential and Commercial Service
- Accredited Technicians
- Radio Dispatched Trucks
- Prompt Fuel Oil Deliveries
- Emergency Service
- Worry-Free Service Plans
- Duct Work
- Service on All Makes

**STATE LICENSED • BONDED - INSURED**

Call Us For Your Heating Oil Needs ... Prompt Delivery. Affordable Rates

**703-494-2855**

Call Us for Fast, Friendly Service & a Free Estimate  
[www.leonardsplaine.com](http://www.leonardsplaine.com)

Serving The Communities Of Burke, Clifton, Fairfax Station, Lorton And Southern Springfield



— Active Roster Continued —

Newsome, Warren (7)  
Plumbing/Mechanical Inspector  
Hanover County  
PO Box 470  
Hanover, VA 23069  
804-730-6040  
804-537-6465 FAX

Nicely, Brandon (3)  
Building Official  
Botetourt County  
1 West Main Street, Box 2  
Fincastle, VA 24090  
540-473-8248  
540-473-8304 FAX  
bnicely@pgroup.net

Nick, Daniel (1)  
Mechanical Inspector  
Loudoun County  
PO Box 7000 MSC 60B  
Leesburg, VA 20177-7000  
703-737-8985  
703-737-8546 FAX

Nickell, Michael (2)  
Building Official  
County of Augusta  
PO Box 590  
Verona, VA 24482-0590  
540-245-5717  
540-245-5721 FAX  
bi@co.augusta.va.us

O

Olszewski, Thomas (6)  
Combination Residential  
Building Inspector  
Chesterfield County  
9800 Government Center Parkway  
Chesterfield, VA 23838  
804-381-8682  
804-778-7512 FAX  
olszewskit@chesterfield.gov

Orr, Bob (5)  
Senior Building Inspector  
Culpeper County  
302 N. Main Street  
Culpeper, VA 22701  
540-727-3405  
540-727-3461 FAX  
borr@culpepercounty.gov

Orrison, John (1)  
Building Official  
Town of Herndon  
PO Box 427  
Herndon, VA 20170  
703-435-6850  
703-318-8492 FAX  
john.orrison@town.herndon.va.us

Owens, Ricky (6)  
Plumbing Inspector  
City of Richmond  
900 East Broad Street, #110  
Richmond, VA 23219  
804-646-6979  
804-646-6948 FAX  
owensra@ci.richmond.va.us

P

Payne, Donald Lee (1)  
Plumbing Inspector  
Loudoun County  
PO Box 7000 MSC 60B  
Leesburg, VA 20177-7000  
703-737-8855  
703-737-8546 AX

Pearce, Randy (6)  
Building Official  
City of Emporia  
PO Box 511  
Emporia, VA 23847  
434-634-6315  
434-634-0003 FAX  
rpearce@ci.emporia.va.us

Perrella, Gary (1)  
Plumbing Inspector  
Loudoun County  
PO Box 7000 MSC 60B  
Leesburg, VA 20177-7000  
703-737-8299  
703-737-8546 FAX

Perry, Kevin W. (5)  
Residential Inspector  
Spotsylvania County  
10304 Spotsylvania Ave, Suite 400  
Fredricksburg, VA 22408  
540-507-7244  
540-710-7119 FAX  
KPerry@spotsylvania.va.us

Phelps, Richard (3)  
Mechanical Inspector  
City of Danville  
PO Box 3300  
Danville, VA 24540  
434-799-5263  
434-799-8919 FAX  
phelpsr@ci.danville.va.us

Phipps, Leonard (8)  
Mechanical Inspector  
City of Chesapeake  
PO Box 15225  
Chesapeake, VA 23322  
757-382-6018  
757-382-8448 FAX

Poston, Paul (2)  
Building Inspector II  
Frederick County  
107 N. Kent Street  
Winchester, VA 22601  
540-665-5656

Proctor, Jack (6)  
Honorary Member, DHCD  
501 N. Second Street  
Richmond, VA 23219  
804-371-7184  
804-371-7092 FAX

Puffinberger, Jr., E. F. "Mike" (2)  
Inspector  
Frederick County  
107 North Kent Street  
Winchester, VA 22601  
540-665-5656  
540-678-0682 FAX

Pylant, Ray (1)  
Building Official  
Fairfax County  
12055 Government Center Pkwy  
Fairfax, VA 22035  
703-324-1910  
703-324-1846 FAX  
ray.pylant@fairfaxcounty.gov

R

**Redifer, Michael D.** (8)  
Life Member  
Building Official  
City of Newport News  
2400 Washington Avenue  
Newport News, VA 23607  
757-926-8865  
757-926-8311 FAX  
mredifer@nngov.com

Reed, Gregory (1)  
Plumbing Inspector  
Loudoun County  
PO Box 7000 MSC 60B  
Leesburg, VA 20177-7000  
571-258-3144  
703-737-8546 FAX

Revels, Gregory (6)  
Building Official  
Henrico County  
PO Box 27032  
Richmond, VA 23273  
804-501-4374  
804-501-4984 FAX  
rev04@co.henrico.va.us

Rexrode, Charles (2)  
Building Codes Inspector  
City of Harrisonburg  
409 South Main Street  
Harrisonburg, VA 22802  
540-432-7700  
540-432-7777 FAX  
duker@ci.harrisburgva.gov

Rigney, Jerry (3)  
Director of Inspections  
City of Danville  
PO Box 3300  
Danville, VA 24540  
804-799-5263  
804-797-8919 FAX  
rignejd@ci.danville.va.us

Rimel, III, Paul (2)  
Code Inspector II  
City of Staunton  
116 West Beverly Street  
Staunton, VA 24401  
540-332-3862  
540-332-3807 FAX  
rimelpm@ci.staunton.va.us

Rinker, Jr., Larry G. (1)  
Mechanical Inspector  
Loudoun County  
PO Box 7000 MSC 60B  
Leesburg, VA 20177-7000  
703-771-5503  
703-737-8546 FAX

		<b>BECK COHEN</b>
		
Plumbing / Air Conditioning / Heating / Electrical		
(434) 296-0129 Fax (434) 295-3439		
215 Avon Street, Charlottesville, VA 22902		

Roberts, Michale (4)  
Building Inspector  
Grayson County  
PO Box 217  
Independence, VA 24348  
276-773-2322  
276-773-3673 FAX

Robinson, JR., William T. (8)  
Cross Connection Specialist  
City of Norfolk  
400 Granby Street  
Norfolk, VA 23510  
757-664-6819  
757-664-6841 FAX  
William.robinson@norfolk.gov

Rogers, Emory (6)  
Director, DHCD  
501 N. Second Street  
Richmond, VA 23219  
804-371-7151  
804-371-7092 FAX

Roop, Chad (1)  
Combination Inspector  
Prince William County  
1 County Complex Court  
Prince William, VA 22192  
703-792-7162  
croop@pwcgov.org

Ross, John  
Technical Assistant  
Giles County  
315 N. Main Street  
Pearisburg, VA 24134  
540-921-2527  
540-921-1846 FAX  
jross@gilescounty.org

Rubino, Donna (1)  
Plan Reviewer  
Prince William County  
5 County Complex Court  
Prince William, VA 22192  
703-792-4459  
703-792-7054 FAX  
drubino@pwcgov.org

S

Sanchez, Al (1)  
Plan Reviewer  
Fairfax County  
12055 Government Center Pkwy  
Fairfax, VA 22035  
703-324-1681  
703-324-1614 FAX  
al.sanchez@fairfaxcounty.gov

Sanderson, John (6)  
Plumbing/Mechanical Inspector  
Chesterfield County  
PO Box 40  
Chesterfield, VA 23832  
804-317-6418  
804-778-7512 FAX  
sandersonj@chesterfield.gov

Sargent, William D. (1)  
Chief Plumbing Inspector  
Loudoun County  
PO Box 7000 MSC 60B  
Leesburg, VA 20177-7000  
703-771-5685  
703-737-8546 FAX  
m-40419@aol.com

Schnetzler, Erich (3)  
Code Official  
Rockbridge County  
150 South Main Street  
Lexington, VA 24450  
540-463-9361  
540-463-5981 FAX  
erich\_schnetzler@co.rockbridge.va.us

Schwind, William M. (5)  
Building Official  
Orange County  
PO Box 111  
Orange, VA 22942  
540-672-4574  
540-672-0164 FAX  
ocinspector@orangecova.com

Scofield, Matt (8)  
Mechanical Inspector  
City of Virginia Beach  
2405 Courthouse Drive  
Virginia Beach, VA 23456  
757-427-8065  
757-427-5777 FAX  
gscofield@vbgov.com

Seay, Jr., John B. (5)  
Commercial Plumbing Inspector  
Albemarle County  
401 McIntire Rd, #211  
Charlottesville, VA 22902  
434-296-5832 Ext 3237  
434-972-4126 FAX  
jseay@albemarle.org

Severson, James A. (6)  
Plumbing/Mechanical Inspector  
City of Petersburg  
106 West Tabb Street  
Petersburg, VA 23803  
804-733-2409  
804-863-2780 FAX

Shapiro, Steven (8)  
Chief Building Official  
City of Hampton  
22 Lincoln Street  
Hampton, VA 23669  
757-727-6246  
757-727-6557 FAX  
sschapiro@hampton.gov

Sheppard, Steven (8)  
Senior Code Specialist  
City of Norfolk  
400 Granby Street  
Norfolk, VA 23503  
757-664-6548  
757-664-6897 FAX  
steve.sheppard@norfolk.gov

Showman, Geary (2)  
Building Code Official  
Shenandoah County  
600 N. Main Street, Suite 107  
Woodstock, VA 22664  
540-459-6185  
540-459-6193 FAX  
gshowman@shenandoahcountyva.us

Silveus, Steven (1)  
Plumbing Inspector  
Loudoun County  
PO Box 7000 MSC 60B  
Leesburg, VA 20177-7000  
703-771-5497  
703-737-8546 FAX

Smallwood, Sr., Charles (1)  
Mechanical Inspector  
Loudoun County  
P.O. Box 7000 MSC 60B  
Leesburg, VA 20177-7000  
703-771-5066  
703-737-8546 FAX

Smith, Charles (1)  
Plumbing Inspector  
Loudoun County  
PO Box 7000 MSC 60B  
Leesburg, VA 20177-7000  
703-737-8986  
703-737-8546 FAX

Smith, Douglas (8)  
Code Official  
Town of Cape Charles  
2 Plum Street  
Cape Charles, VA 23310  
757-331-3259 Ext 16  
757-331-4820 FAX  
codeofficial@capecharles.org

Smith, Ken (1)  
Master Combination Inspector  
Fairfax County  
12055 Government Center Pkwy  
Fairfax, VA 22035  
703-324-1703  
703-324-1846 FAX  
kenneth.smith@fairfaxcounty.gov

Smith, Sharon (6)  
Certification Manager, DHCD  
501 N. Second Street  
Richmond, VA 23219  
804-371-7185  
804-371-7092 FAX  
sharon.finan@dhcd.virginia.gov

— Active Roster Continued —

Smith, Wes (5)  
Building Official  
Madison County  
PO Box 1206  
Madison, VA 22727  
540-948-6102  
540-948-3939 FAX  
wsmith@madisonco.virginia.gov

Snider, Jason D.  
Building Inspector  
County of Rockbridge  
150 S. Main Street  
Lexington, VA 24450  
540-463-9361  
540-463-5981 FAX  
jason\_snider@co.rockbridge.va.us

**Snyder, Sr., Kenneth R.** (2)  
Life Member  
41 Fairmont Drive  
Staunton, VA 24401  
540-885-2971  
kenandbarbva@aol.com

Snyder, Paul (5)  
Building Official  
Louisa County  
PO Box 160  
Louisa, VA 23093  
540-967-3430  
540-967-3458 FAX  
psnyder@louisa.org

Spence, Brown (1)  
Chief Mechanical Inspector  
Loudoun County  
PO Box 7000 MSC 60B  
Leesburg, VA 20177-7000  
703-771-5059  
703-737-8546 FAX  
bspence@loudoun.gov

Stanley, Dennis (3)  
Assistant Building Official  
City of Salem  
PO Box 869  
Salem, VA 24153  
540-375-3036  
540-375-3003 FAX  
dstanley@ci.salem.va.us

Stephen, Darryl (8)  
Senior Mechanical Inspector  
City of Norfolk  
400 Granby Street  
City of Norfolk, VA 23510  
757-664-6562  
757-664-6841 FAX  
Darryl.stephen@norfolk.gov

Stevens, Eric C. (1)  
Plumbing Inspector  
Prince William County  
1 County Complex Court  
Prince William, VA 22192  
703-792-6969  
703-580-1578 FAX  
estevens@pwcgov.org

Stevens, Michael (1)  
Plumbing Inspector  
Prince William County  
1 County Complex Court  
Prince William, VA 22192  
703-792-6969  
mstevens@pwc.org

Stewart, Danny L. (8)  
Plumbing Inspector  
City of Virginia Beach  
2405 Courthouse Drive  
Virginia Beach, VA 23456  
757-385-8066  
757-385-5777 FAX

Stickel, Donald (3)  
Building Official  
Pittsylvania County  
53 North Main Street  
Chatham, VA 24531  
434-432-7755  
434-432-7919 FAX  
d.stickel@pittgov.org

**Stover, Douglas L.** (2)  
Life Member  
Rockingham County (Ret.)  
PO Box 1252  
Harrisonburg, VA 22801  
540-564-3030  
540-434-7163 FAX

Stump, Gary (1)  
Building Inspector II  
Town of Herndon  
PO Box 427  
Herndon, VA 20172  
703-435-6850  
703-318-8492 FAX  
gary.stump@herndon-va.gov

Strausbaugh, Shan (1)  
Plans Examiner  
Arlington County  
2100 Clarendon Blvd, Suite 804  
Arlington, VA 22201  
703-228-3874  
703-228-3777 FAX  
sstrausbaugh@arlingtonva.us

Street, John (8)  
Combination Inspector  
City of Williamsburg  
401 Lafayette Street  
Williamsburg, VA 23105  
757-220-6136  
757-259-3798 FAX  
jstreet@williamsburg.gov

Stubanus, Gregory (2)  
Code Enforcement  
City of Waynesboro  
250 S. Wayne Avenue, Rm #208  
Waynesboro, VA 22980  
540-942-6628  
540-942-6770 FAX  
stubanusgc@ci.waynesboro.va.us

Sulzer, Caleb (5)  
Building Inspector  
Louisa County  
PO Box 160  
Louisa, VA 23093  
540-967-3430  
540-967-3486 FAX  
csulzer@louisa.org

Sutton, Chuck (8)  
Inspector Coordinator  
City of Virginia Beach  
2405 Courthouse Drive  
Virginia Beach, VA 23456  
757-385-4211  
757-385-5777 FAX  
cwsutton@vbgov.com

Swortzel, Michael (2)  
Inspector  
Augusta County  
PO Box 590  
Verona, VA 24482  
540-245-5717  
540-245-5721 FAX  
bi@co.augusta.va.us

---

T

---

Thrash, Mark Gregory (6)  
Residential Combination Inspector  
Chesterfield County  
PO Box 40  
Chesterfield, VA 23832  
804-814-6984  
thrash@chesterfield.gov

Thuot, Michael  
Retired  
3197 Adam Keeling Road  
Virginia Beach, VA 23452  
540-349-8748  
mthout@aol.com

Tillman, L. Del (8)  
Sr. Plumbing/Mechanical Inspector  
City of Hampton  
22 Lincoln Street  
Hampton, VA 23669  
757-727-6790  
757-727-6557 FAX

Tobin, Sr., Cordell S. (1)  
Construction Plans Examiner  
Arlington County  
2100 Clarendon Blvd, Suite 800  
Arlington, VA 22201  
703-228-3874  
703-228-7046 FAX  
ctobin@co.arlington.va.us

**Tomberlin, Guy** (1)  
Life Member  
Chief Plumbing Inspector  
Fairfax County  
12055 Government Center Pkwy  
Fairfax, VA 22035  
703-324-1611  
703-324-1846 FAX  
guy.tomberlin@fairfaxcounty.gov



FITZGERALD**ART**&DESIGN<sup>LLC</sup>

703-527-1238

info@fitzart-d.com



*Tribute to William "Til" Hazel, 20" x 16", mixed media. 2007*

www.fitzart-d.com

— Active Roster Continued —

Trenary, John S. (2)  
Building Official  
Frederick County  
107 North Kent Street  
Winchester, VA 22601  
540-665-5656  
540-678-0682 FAX  
jtrenary@co.frederick.va.us

Toney, Chris (5)  
Combination Inspector  
Spotsylvania County  
10304 Spotsylvania Avenue  
Fredericksburg, VA 22408  
540-507-7238  
mtoney@spotsylvania.va.us

Truslow, Paul (5)  
Codes Inspector  
Nelson County  
PO Box 336  
Lovingson, VA 22949  
434-263-7080  
434-263-7086 FAX  
ptruslow@nelsoncounty.org

---

V

Vannoy, Johnny (1)  
Combination Inspector  
Fairfax County  
12055 Government Center Pkwy,  
Suite 634  
Fairfax, VA 22035  
703-475-0615  
703-324-3901 FAX  
johnny.vannoy@fairfaxcounty.gov

---

W

Walker, Thomas (6)  
Plumbing Inspector  
City of Richmond  
900 East Broad Street, #110  
Richmond, VA 23219-6505  
804-780-6962  
804-785-6948 FAX

Ward, Allen (8)  
Building Official  
Mathews County  
PO Box 839  
Mathews, VA 23109  
804-725-7171  
804-725-0560 FAX

Ward, Danny Roy (5)  
Building Inspector  
Madison County  
PO Box 1206  
Madison, VA 22727  
540-948-6102  
540-9483939 FAX  
dward@madisonco.virginia.gov

Watts, Marion (4)  
Building Official  
Town of Abingdon  
PO Box 789  
Abingdon, VA 24212  
276-628-6611  
276-628-9986 FAX  
mdwatts@abingdon.com

Werres, Joseph (5)  
Inspector/Project Manager  
Albemarle County  
401 McIntire Rd, #211  
Charlottesville, VA 22902  
434-296-5816  
434-293-0294 FAX

Westfall, Bobby (1)  
Plumbing Inspector  
Loudoun County  
PO Box 7000, MSC 60B  
Leesburg, VA 20177-7000  
703-737-8646  
703-737-8546 FAX

White, Barry (6)  
Combination Inspector  
Chesterfield County  
PO Box 40  
Chesterfield, VA 23832  
804-748-1210  
804-778-7512 FAX  
whiteb@chesterfield.gov

Williams, Michael A. (2)  
Plans Examiner  
City of Harrisonburg  
409 South Main Street  
Harrisonburg, VA 22802  
540-432-7700  
540-432-7777 FAX  
mikew@harrisonburgva.gov

Wills, Andrew (5)  
Building Inspector  
Fluvanna County  
PO Box 540  
Palmyra, VA 22963  
434-591-1935  
434-591-1911 FAX  
awills@co.fluvanna.va.us

Wilson, Brian (8)  
Cross Connection Specialist  
City of Norfolk  
400 Granby Street  
Norfolk, VA 23510  
757-664-6840  
757-664-6841 FAX  
brian.wilson@norfolk.gov

Wilson, Kenny (3)  
Combination Inspector  
Rockbridge County  
150 South Main Street  
Lexington, VA 24450  
540-463-9361  
540-463-5981 FAX  
kenny\_wilson@rockbridge.va.us

Windon, James  
Chief Plumbing Inspector  
Harford County  
220 South Main Street  
Belair, MD 21014  
410-638-3215  
410-879-8203 FAX  
plumbing@co.ha.md.us

Witt, Richard (6)  
Assistant Building Official  
Chesterfield County  
PO Box 40  
Chesterfield, VA 23832  
804-751-4161  
804-757-4713 FAX  
witt@chesterfield.gov

Wood, Murphy (3)  
Building Inspector  
City of Salem  
PO Box 869  
Salem, VA 24153  
540-375-3036  
mwood@salemva.gov

Woolard, Wayne (8)  
Plumbing/Mechanical Inspector  
City of Hampton  
22 Lincoln Street  
Hampton, VA 23669  
757-727-6286  
757-727-6557 FAX  
wwoolard@hampton.gov

Woolford, Eric (5)  
Building Inspector  
Greene County  
PO Box 358  
Stanardsville, VA 22973  
434-985-5204  
434-985-1459 FAX  
ewoolford@gcva.us

---

Y

Yoder, Leon (8)  
Plans Reviewer  
City of Norfolk  
400 Granby Street  
Norfolk, VA 23510  
757-664-6815  
757-664-6841 FAX  
Leon.Yoder@norfolk.gov

Yun, Sunguk (1)  
Critical Structures  
Fairfax County  
12055 Government Center Pkwy  
Fairfax, VA 22035  
703-324-1051  
sunguk.yun@fairfaxcounty.gov

---

Z

Ziegler, Joseph (5)  
Residential Combination/Commercial  
Inspector  
Spotsylvania County  
10304 Spotsylvania Avenue, Ste. 400  
Fredericksburg, VA 22408  
540-507-7249  
540-710-7119 FAX  
jziegler@spotsylvania.va.us

---

Updated as of March 2008



# — 2007-8 Associate Member Roster —

**Bold Type** indicates "Life Member" status

Allen, Marlund R.  
COO  
LA Lacy, Inc.  
900 Harns Street  
Charlottesville, VA 22903  
434-296-7542  
434-293-9073 FAX  
marlund@lalacy.com

Anderson, Kenneth  
Virginia Beach City Public Schools  
29525 N. Landing Rd  
Virginia Beach, VA 23456  
757-427-5300  
757-427-5558 FAX  
keanders@vbcps.k12.va.us

Archer, Bradford  
Construction Management &  
Administration  
1734 Seibe Drive  
Roanoke, VA 24012  
540-344-7939  
540-344-3657 FAX

Bates, Jr., William T.  
Foley Plumbing  
6418 E Old Meetze Rd  
Warrenton, VA 20187  
540-428-3290  
540-428-3295 FAX  
foleyking@verizon.net

Becker, David  
Potomac Energy Group  
20 S. Quaker Lane  
Alexandria VA 22314  
703-683-5000  
daveb@pegroup.net

Bess, Robert M.  
Plumbers/Steamfitters Local #1  
701 Stockton Street  
Richmond, VA 23224  
804-231-4232  
804-231-4235 FAX

Borden, Fred W.  
Fred W. Borden, Inc.  
4174-A Old Stockyard Rd.  
Marshall, VA 20115  
703-378-8484  
703-378-6359 FAX  
fwbordenplumbing@aol.com

Buckner, William W.  
Greenbeck Enterprises  
608 Van Fossen Street  
Winchester, VA 22601  
540-662-7638  
540-662-1773 FAX  
bbuckner@visuallink.com

Brown, Jeremy  
Codes & Regulatory Manager  
789 N. Dixboro Rd.  
Ann Arbor, MI 48105  
734-769-5796  
737-827-7129 FAX  
brown@nsg.org

Burkert, Chris  
Capital Inspections  
P.O. Box 1321  
Centreville, VA 20120  
703-222-8826  
cab2326@aol.com

Cathell, Edward K.  
Walter E. Cathell Assoc. Inc  
6609 York Road  
Baltimore, MD 21212  
410-323-9881  
410-433-1548 FAX  
ekcathell@yahoo.com

Cole, Stanton R.  
Purchasing/Fleet Manager  
Southern-Air, Inc.  
2655 Lakeside Drive  
Lynchburg, VA 24502  
434-385-1261  
434-385-7515 FAX  
Ronnie.Cole@southern-air.com

Colton, Richard B.  
Master, Inc.  
7891 Beechcraft Ave  
Gaithersburg, MD 20879  
301-252-3308  
301-258-7368 FAX  
bruce.colton@mastersco.com

Conover, David R.  
Senior Advisor, ICC  
500 New Jersey Ave., NW,  
Suite 600  
Washington, DC 20001  
202-370-1800 Ext 6244  
DConover@iccsafe.org

Crigler, Laurie & Daniel  
L & D Associates  
P.O. Box 418  
Aroda, VA 22709  
540-948-6230  
540-948-5617 FAX  
lcrigler@ns.gemlink.com

Edwards, Tim  
Regional Engineer  
Advanced Drainage Systems  
13320 Meredith Pointe Way  
Chesterfield, VA 23832  
804-922-2289  
804-739-2866 FAX  
tim.edwards@ads-pipe.com

Finney, Jeffrey Dean  
Nationwide Custom Homes  
P.O. Box 5511  
Martinsville, VA 24115  
540-632-7100  
540-632-1181 FAX  
jfinney@nationwidecustomhomes.com

Given, Alan  
Parish Services  
7865 Coppermine Drive  
Manassas, VA 20109  
703-330-5748  
703-330-0599 FAX  
alange@parishservices.com

**Hardee, Sr., Cecil F.**  
Life Member  
203 Bayswater Ct.  
New Bern, NC 28562

Hibbs, Evan C.  
Evan C. Hibb, Inc.  
957 Chautauqua Ave  
Portsmouth, VA 23707  
757-393-7401  
757-393-7403 FAX  
even@evanhibbs.com

Jinks, Scott  
J & S Plumbing  
P.O. Box 1628  
Manassas, VA 20108  
703-721-5095  
royalflush0108@yahoo.com

Johnston, David  
5111 Lavery Court  
Fairfax, VA 22032  
703-503-0644

Kalish, Susan  
National Fireplace Institute  
1901 N. Moore St. Ste 600  
Arlington, VA 22209  
703-524-8030  
703-522-0548 FAX  
kalish@hpba.org

Kellogg, Stephen  
Water Solution Account Executive  
4987 Cleveland Street, #106  
Virginia Beach, VA 23462  
757-490-9110  
757-490-9001 FAX  
dryit@waterdamagessolutions.biz

Kelley, George "Duke"  
GSSN  
102 Lipizzaner Court  
Stephens City, VA 22655  
540-868-1146  
540-868-1146 FAX  
gssn-corp@hotmail.com

Kidd, Jerry  
Beck Cohen Inc  
215 Avon Street  
Charlottesville, VA 22902  
434-296-0129  
434-295-3439 FAX  
beckcohen@yahoo.com

(Continued on next page)

— Associate Roster Continued —

Kreutzer, Tom  
Woodbridge Plumbing, Inc.  
2705 Code Way  
Woodbridge, VA 22192  
703-494-9666  
703-494-0739 FAX

Leonard, Gary E.  
Leonard-Splaine Company, Inc.  
13300 Occoquan Road  
Woodbridge, VA 22191  
703-494-2855  
703-494-8305 FAX  
Leonard.gary@hotmail.com

**Maher, J. Richard**  
Life Member  
307 Cadmus Circle  
Gordonsville, VA 22942  
703-832-5313

Maupin, David  
W.E. Brown, Inc.  
915 Monticello Rd  
Charlottesville, VA 22902  
434-295-1177  
434-979-1394 FAX  
dave@webrown.com

McMahon, James  
Cast Iron Soil Pipe Inst.  
925 Seaman Ave.  
Beachwood, NJ 722  
703-644-5146  
castironjim@mindspring.net

Mitchell, Sr., Radford H.  
Virginia Beach City Public Schools  
4400 Virginia Beach Blvd.  
Virginia Beach, VA 23462  
757-473-5000  
757-473-5004 FAX  
ramitchell@vbcpes.k12.va.us

**Muncy, James B.**  
Life Member  
President, MAMS, Inc.  
7711 Mendota Drive  
Richmond, VA 23229  
804-288-5664  
804-282-1620 FAX

Nuckols, J.C.  
Nangle, Heather  
PMPV Executive Director  
P.O. Box 307  
Fairfax, VA 22039  
800-947-7450  
800-947-7415 FAX  
hnangle@mac.com

Olsen, Ricky  
Fort Hunt Plumbing  
1906 Mallinson Way  
Alexandria, VA 22308  
703-799-9356  
703-7991754 FAX  
plumb369@aol.com

Outland, John Jay  
Prince William County School Board  
P.O. Box 389  
Manassas, VA 20108  
703-791-7221  
703-791-7481 FAX  
outlandj@pwcs.edu

Peed, Gary  
President, Peed Plumbing Inc.  
11721 Pump Station Way  
Manassas, VA 20109  
571-229-1234  
garypeed@peedplbg.com

Pittenger, Robert E.  
Beach Services  
9553 First View St.  
Norfolk, VA 23503  
757-480-7260  
bchplmbserve@att.net

Qualified Gas Contractors Assoc.  
of South Hampton Roads  
5100 E. Virginia Beach Blvd  
Norfolk, VA 23503  
757-466-5579  
757-466-5437 FAX

Rao, Jr., Charles T.  
Richmond Marketing, Inc.  
2535 Mechanicsville Turnpike  
Richmond, VA 23223  
804-643-7355  
804-643-7380 FAX  
rmi@ricmrk.com

Sargeant, Jonathan D.  
National Accounts Manager  
Jay R. Smith Manufacturing Co.  
4024 St. Elmo Avenue  
Chattanooga, TN 37409  
423-883-3137  
423-207-4840 FAX  
Jon.Sargeant@jrsmith.com

Simounet, Craig  
President, Capital Mechanical, LLC  
45037 Moran Drive  
Dulles, VA 20166  
703-443-9323  
703-433-9579 FAX  
csimounet@aol.com

Smith, Sr., Oscar  
Oscar W. Smith Mechanical  
2612 Jackson Drive  
Salem, VA 24153  
540-389-8041  
540-387-4590 FAX

Sovern, Robert J.  
Atlantic Constructors, Inc.  
1401 Battery Brooke Parkway  
Richmond, VA 23237  
804-222-3400  
804-233-5970 FAX  
robertsovern@atlanticconstructors.com

**Steinle, Jim**  
Life Member  
Owner  
Atomic Plumbing  
1377 London Bridge Road  
Virginia Beach, VA 23453  
757-464-2934  
757-363-8403 FAX  
Jim@atomicplumbing.com

Stilwell, P. Wayne  
President  
PW. Stilwell Plumbing/Htg  
13482 Still Well Lane  
Brandy Station, VA 22714  
540-825-0025  
540-825-0650 FAX

Strickler, Jasper  
Post Office Box 728  
Stuarts Draft, VA 24477  
540-942-5207  
strickler@yahoo.com

Tamres, Joseph  
Hartford Steam Boiler, Insp  
2563 James Madison Cr  
Herndon, VA 20171  
703-713-3467  
703-713-3467 FAX  
joseph\_tamres@hsb.com

Tryall, Allen  
Beck Cohen, Inc  
215 Avon Street  
Charlottesville, VA 22902  
434-296-0129  
434-295-3439 FAX

West, Charles H.  
Wells 7 West, Inc  
P.O. Box 129  
Murphy, NC 28906  
828-837-2437  
828-837-3152 FAX

Wiggins, John R. (P.E.)  
Underwriters Laboratory  
12 Laboratory Dr  
RTP, NC 27709  
919-549-1502  
919-547-6454 FAX  
johnr.wiggins@us.ul.com

Wood, Tommy  
CEO  
Woodbridge Plumbing, Inc  
2705 Code Way  
Woodbridge, VA 22192  
703-494-9666  
703-494-0739 FAX  
twood@woodbridgeplumbing.com

# — Membership Application Form —

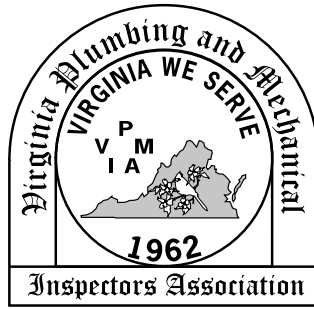

**I the undersigned,** hereby make application for membership, and if accepted, I agree to abide by the Constitution and By-laws of the Association, perform all requested duties and support the Association to the best of my abilities. I understand the membership fee shall cover the period from January 1<sup>st</sup> to December 31<sup>st</sup>, any payment received during the year shall cover only the remainder of the year.

Name \_\_\_\_\_

Title \_\_\_\_\_

Jurisdiction or Firm \_\_\_\_\_

Address \_\_\_\_\_

City \_\_\_\_\_ State \_\_\_\_\_ Zip \_\_\_\_\_

Telephone No. \_\_\_\_\_ Fax \_\_\_\_\_

E-Mail Address \_\_\_\_\_

Signature \_\_\_\_\_ Date \_\_\_\_\_

ACTIVE MEMBERSHIP FEE: \$30.00  
Active members must be employed by a government agency.

{ } Please check this block if you are a designated ICC voter, representing your municipality or jurisdiction.

ASSOCIATE MEMBERSHIP FEE: \$35.00  
Associate members shall consist of persons interested in assisting the Association in promoting the safety, health and welfare of the public. Associate members must be approved, for membership in the Association, by the Board of Directors.

Make checks payable to: Virginia Plumbing and Mechanical Inspectors Association (VPMIA)

**Please Mail To:**

Geary Showman, BCO  
VPMIA Executive Secretary  
600 N. Main Street  
Woodstock, VA 22664-3551

<b>VPMIA USE ONLY</b>
Date: _____
Check Number: _____
Amount(\$): _____

More than 40 years dedication to the code enforcement community.

2005 ICC Merit Award Recipient for the Chapter of the Year Contest.

Connect with VPMIA today.

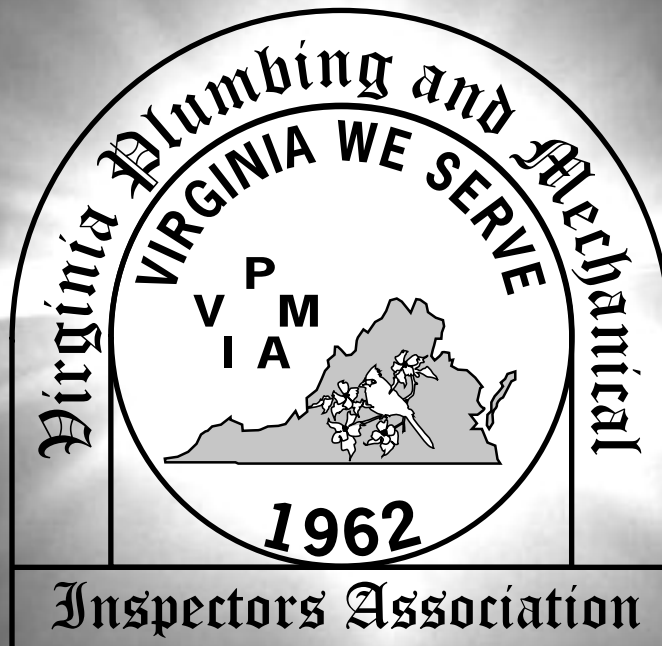

*VPMIA is an*

*association of code professionals dedicated to promotion*

*VPMIA is an association of code professionals dedicated to promotion of uniform enforcement and development of the codes throughout the Commonwealth to assure the health, safety, and welfare of its citizens and any one who may live, work, or visit the state of Virginia.*

*The pursuit of this endeavor is achieved through close, open, and equal working relationships with design professionals, builders, contractors, material manufacturer's and others involved in the construction industry. VPMIA supports the ICC, its goals and mission.*

**Virginia Plumbing and Mechanical Inspectors Association**  
**www.vpmia.org**

# Thinking green. It's a Ductmate thing.



At Ductmate, we've been a product innovator and engineering solutions provider for more than 30 years. Through those decades, we've garnered over two dozen worldwide and U.S. patents, and a litany of HVAC product awards. But this one is special. The Green Building Alliance® Product Innovation Grant is a recognition of our ability to invent, grow, and develop product innovations that promise to make a significant impact on the green building industry.

This grant is awarded to projects that seek to develop and introduce new and enhanced green building products. GreenSeam™ is a unique self-sealing snap-lock pipe, designed to provide increased efficiency for residential and commercial HVAC applications. Engineering simplicity is the key to GreenSeam's effectiveness. By integrating a gasket into the entire length of the longitudinal snap-lock seam, GreenSeam reduces leakage by 95% along the longitudinal seam without depending on external tapes or sealants. GreenSeam has quickly become a cost-effective key component of today's sustainable HVAC systems.

So, while we are honored to have received this recognition, we see it as simply the result of doing what we do. Thinking Green. It's a Ductmate thing. To learn more, call us at 1-800-245-3188, or visit our Online Information Center at [www.ductmate.com](http://www.ductmate.com).



One Source. Infinite Solutions.

800-245-3188 • [www.ductmate.com](http://www.ductmate.com)



*GreenSeam's integrated gasket reduces leakage by 95% along the longitudinal seam without the need for sealants.*





7405 ALBAN STATION COURT  
SUITE A-107  
SPRINGFIELD, VA 22150  
(703) 455-5520 (O)  
(703) 455-5530 (F)  
got2fishordie@yahoo.com

ARCHITECTS  ENGINEERS  CONTRACTORS



RESIDENTIAL  COMMERCIAL

# Your Family Deserves The Best.



**For the protection and safety of your family and your home, it pays to hire a professional plumbing-heating-cooling contractor.**

Over 4,100 companies nationwide are qualified members of the Plumbing-Heating-Cooling Contractors Association (PHCC). Each member company stands for the health, safety and comfort of homeowners and protection of our environment. A professional p-h-c contractor will safeguard your home from carbon monoxide poisoning, water damage, sewer gas releases, scalding, mold, waste water leaks,

and potential injuries related to improper installation and maintenance. Whether you're modernizing an entire system or simply need a repair, make sure you choose a trained, full-time professional—not someone who does this type of work "on the side." Do you really want to chance these important and potentially dangerous tasks to a non-professional?



**Be Safe. Be Smart. Hire a PHCC Professional.**

This public service message provided by the PHCC Partners for Professionalism.



For information on how to hire a professional contractor, visit our Web site at [www.phccweb.org](http://www.phccweb.org) and click on Find a Contractor. Or call our toll free number 800-533-7694 and we'll put you in touch with a PHCC member in your area.

# ACCA HVAC DESIGN MANUALS

AS REFERENCED BY THE IRC, IMC, AND IECC

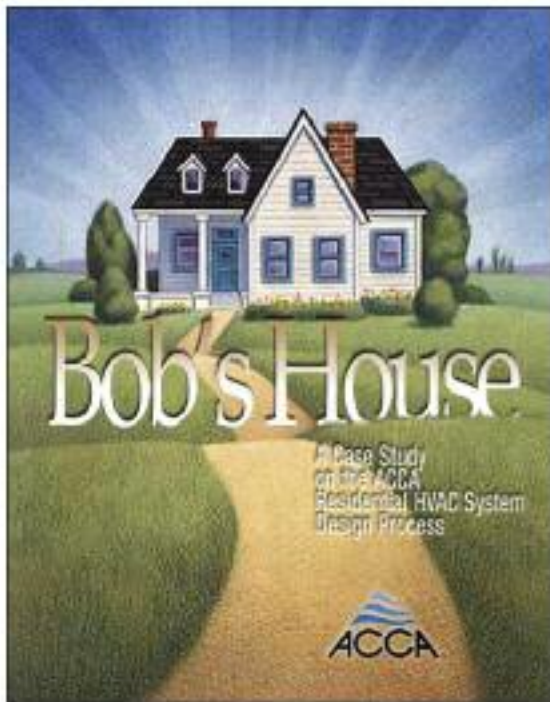

## **Bob's House**

An illustrated guide to the residential HVAC design process  
(ACCA Manual J & D)

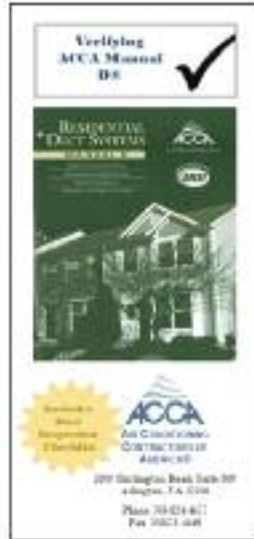
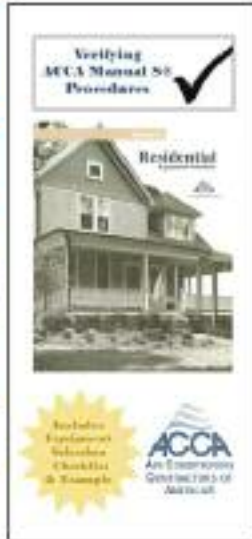
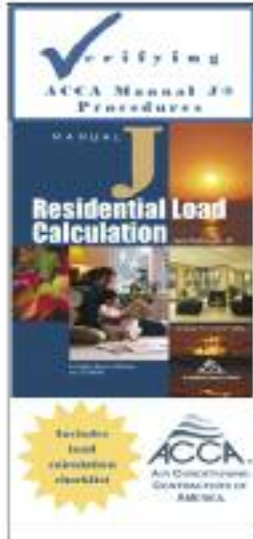
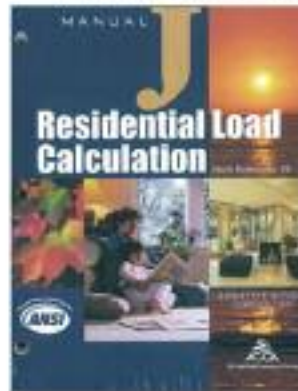

**Free** guides for verifying contractor compliance at:  
[acca.org/tech/codes](http://acca.org/tech/codes)



FOR SUPPORT AND OTHER MEMBERSHIP BENEFITS VISIT [WWW.ACCA.ORG](http://WWW.ACCA.ORG)